



WHEEL LOADER | 411/417

411 – Operating weight: 8722kg Gross engine power: 81kW (109hp) Full turn tipping load: 5451kg Standard shovel capacity: 1.4m³

417 – Operating weight: 9602kg Gross engine power: 97kW (130hp) Full turn tipping load: 6042kg Standard shovel capacity: 1.6m³

FULLY LOADED

The new JCB 411 and 417 Stage V wheel loaders are fully loaded with new and innovative features: A 4% more powerful, efficient and clean Stage V Dieselmix engine. Improved fuel efficiency with new auto engine shutdown feature.

A 4-speed transmission and one of the most comfortable and operator friendly cabs on the market with unbeatable visibility.

With more than 50 years of proven wheel loader production, we're confident you'll be fully impressed with our latest models.

STAGE V





FULLY TESTED.

THE NEW JCB 411 AND 417 HAVE BEEN BUILT USING THE MOST ADVANCED PRODUCTION TECHNIQUES AND PREMIUM COMPONENTRY FOR SUPERIOR STRUCTURAL STRENGTH. THEY'VE BEEN TESTED TO THE LIMIT ON SITES AROUND THE WORLD SO THAT WHEREVER YOU'RE OPERATING, YOU'LL ALWAYS MAINTAIN TOTAL PRODUCTIVITY.

Designed to work harder.

1 Your new 411 or 417 will have benefitted from finite element analysis and rig testing of up to 1 million cycles, to ensure superior structural strength and durability. For further peace of mind, cold cell testing guarantees starting performance down to -20 degrees.

2 High tolerances and accurate location of pins and bushes are guaranteed with JCB's precision machining techniques.

3 State-of-the-art manufacturing processes like robot machining, precision paint technology and innovative assembly techniques help to achieve the very highest levels of build quality.

You can specify a 411 or 417 for heavy-duty applications like waste or corrosive material handling.



The 411 and 417's articulation joint has a heavy-duty box section that's much stronger than a single plate with a boss. Its steering rams are positioned high up and well protected from possible impact and site damage.

Designed to last.

4 A solid cast rear counterweight protects the rear of your 411 or 417, including the rear lights and cooling pack, from damage.

5 You can opt for additional guards on the front screen, lights and rear grille.

For additional protection, there are impact resistant fender edges and trims fitted.

6 Hoses are neatly routed and clamped through the articulation joint, well away from any pinch points.

7 The articulation joint has a heavy-duty centre pin and oversized bush, as well as twin taper roller bearings on the bottom box joints. This enables it to tolerate both vertical and horizontal loadings for greater durability and rigidity.

These machines have integral steel fluid tanks for the ultimate in leak protection; a far superior solution to the plastic tanks favoured by some competitors.

8 New cooling pack sealing and mudguard fitment for greater overall quality.



7



4



5



6

FULLY PRODUCTIVE.

TIME IS OF THE ESSENCE ON ANY WORKSITE, SO THE NEW JCB 411 AND 417 ARE DESIGNED TO PROVIDE THE FASTEST CYCLE TIMES IN THE BUSINESS WITH POWERFUL HYDRAULIC PUMPS, A LOAD SENSING VALVE BLOCK AND 4-SPEED TRANSMISSION AS STANDARD.

Powering it all.

1 The Stage V Dieselmix 4.8 litre engine fitted to the new JCB 411 and 417 wheel loaders produces impressive performance with a substantial 81kW (109hp) on the 411 and 516Nm of torque. Meanwhile the 417 delivers 97kW (130hp) with 550Nm of torque, up on our previous model. What's more, they produce all this at low revs for an incredibly responsive operating experience.

2 Choose the optional JCB Quickhitch and you'll find attachment changing is quick and efficient.

3 Powerful hydraulics result in fast cycle times. The 411 features a 123l/min double gear pump, whilst the 417 model features a single variable displacement piston pump, delivering 156 l/min for increased productivity and excellent multi-function capability.



COMMANDPLUS controls.

A choice of 3 or 4-spool hydraulics gives you the scope for invaluable extra versatility. Flow can be adjusted from the cab via the all-new CommandPlus controls.

Loading productivity

4 Specify your perfect loader arm: HT for parallel lifting and multi-attachment work. Choice of Standard, High lift or Super high lift for applications involving high loading heights, such as hopper and lorry loading. With maximum breakout forces of 70kN, this wheel loader has the power to carry out extremely arduous jobs.

Drivetrain productivity.

5 Our 4-speed transmission gives you a range of gears to suit a wide range of applications. The operator can choose from manual or automatic gear shifting at the press of a button.

6 The transmission disconnect feature performs clutch cut-off for efficient, productive loader control. This feature controls tractive effort via the transmission, diverting maximum power to the loader hydraulics and reducing brake wear and fuel consumption.

7 With a choice of axle options you can tailor performance to any application.

> Open differentials are ideal for hard standing ground conditions.

> Limited slip differential axles increase tractive effort and are perfect for soft muddy ground conditions.



4



4 HT Standard Lift

HT High Lift

HT Super High Lift



5

FULLY POWERED.

THE NEW JCB 411 AND 417 TAKE POWER WITHOUT COMPROMISE TO ANOTHER LEVEL. THEIR CUTTING-EDGE STAGE V DIESELMAX ENGINES BOAST POWER APLENTY, WHILE THEIR EFFICIENT, SMOOTH DRIVELINES AND LOW FUEL CONSUMPTION HELP MAKE YOUR DECISION TO BUY JCB EVEN EASIER.

Powering it all.

- 1 The DieselMAX engine produces high levels of power and torque at engine speeds at low as 1500-1600rpm for efficient matching of the transmission and hydraulics.
- 2 High back-off power brakes reduce viscous drag during roading and rehandling, which improves fuel economy.
- 3 A viscous coupled engine fan automatically adjusts its speed depending on ambient temperature, optimising cooling, saving fuel and lowering noise.



1



2



3

COMMANDPLUS controls.

JCB Smoothride Load Suspension limits shock loadings and therefore reduces material spillage and structural stress, as well as increasing operator comfort. The speed of engagement is adjustable from within the cab using the latest state-of-the-art CommandPlus controls.

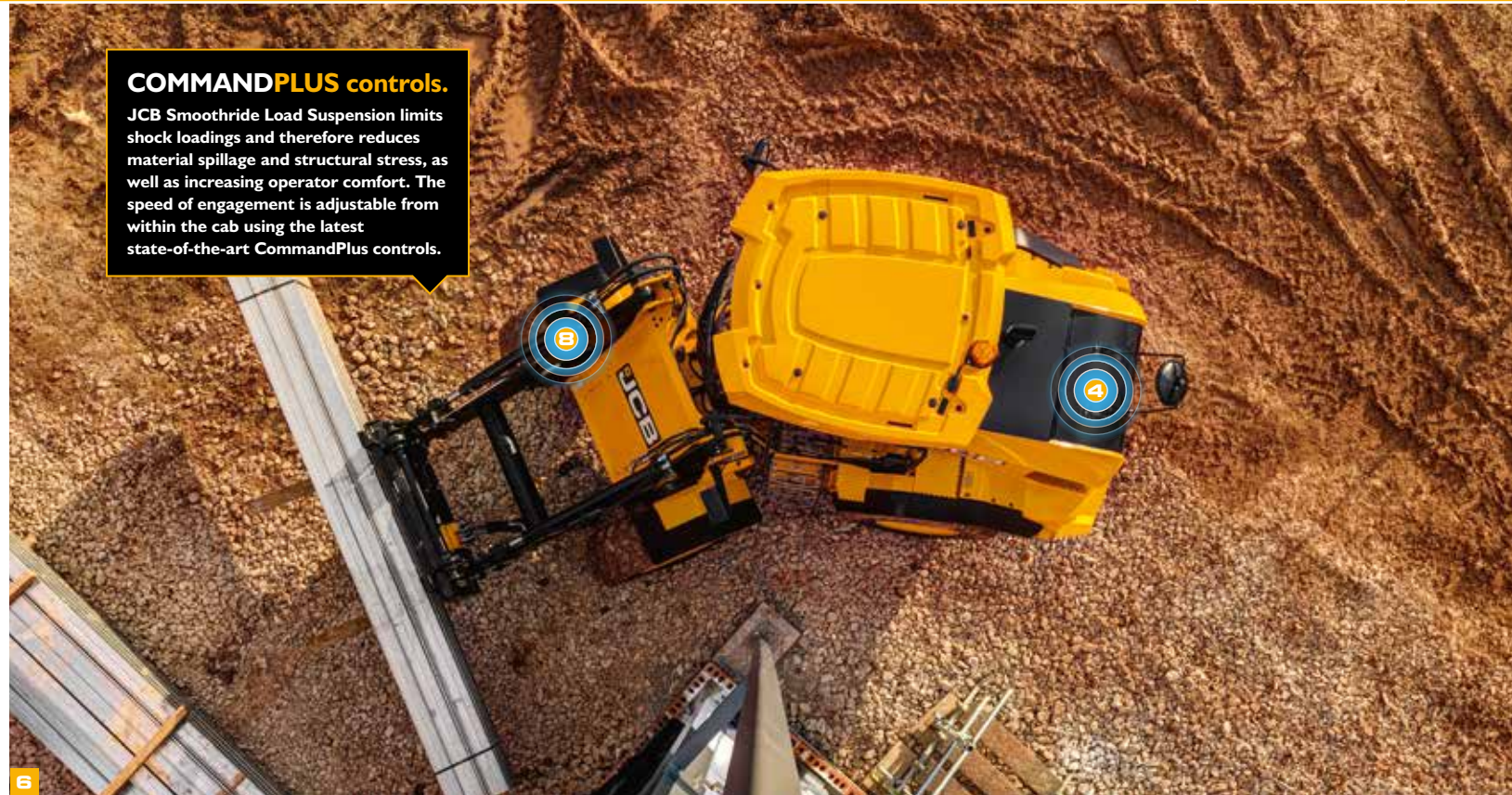

Powering it all (continued).

4 A new auto engine shutdown feature saves fuel by switching off the engine when the machine is left idling. Idle time can be set by the operator from the cab seat.

5 Operating specialist attachments is easy with an in-cab adjustable proportional auxiliary flow rate.

6 Unloaded spool valves in the valve block allow the arms to lower under gravitation rather than hydraulic force; this reduces fuel consumption still further.

7 Selectable loader arm detents let operators control loader arm height limitations, return to dig settings and float functions, improving safety and productivity.

8 JCB's innovative variable displacement pumps feed a load-sensing valve block which only consumes power on demand, providing precise, efficient loader control.

6

Adjustable SRS engagement speed.



Adjustable auxiliary control.



Adjustable reversing fan intervals.

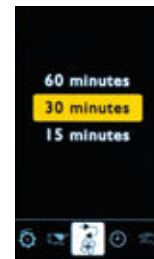

FULLY IN COMMAND.

THE JCB COMMANDPLUS CAB IS ONE OF THE BEST CABS ON THE MARKET, WITH THE LATEST IN ERGONOMIC DESIGN PROVIDING AN OPTIMAL CONTROL LAYOUT AND DRIVER POSITION FOR GREATER COMFORT AND VISIBILITY, ENABLING EVEN GREATER OPERATOR PRODUCTIVITY.

See the difference.

1 The B-pillars are positioned to the same width as the rear of the cab, providing a larger interior with a superb panoramic front windscreen. All switches and auxiliary controls are located on the right-hand B-pillar for easier access.

2 Using your machine's simple, dedicated menu interface is easily done with an intuitive optional rotary controller.

3 Controlling the loader is easy as all of the controls are seat-mounted and even move with the seat suspension. Simply select the control system that's best for your operators: we offer single lever joystick or multi-lever configurations.

4 There are two full colour LCD screens to navigate your machine's operating menus with one doubling as a monitor for the rear-view camera.

For even greater operator comfort, the machines are equipped with end damped steering for smoother steering from lock to lock.



The noise level in the cab is an incredibly low 68dB(A): so quiet you can hardly hear the engine running.

5 To keep the operator environment comfortable for working at all times, we've positively pressurised the cab to eliminate dust and fumes.

6 After extensive research into operator ergonomics, we've devised the Command Driving Position, which boasts the very optimal control layout for a multitude of different driver shapes and sizes. Choose from an air suspension standard seat to a super deluxe half leather seat, featuring fully adjustable heating and cooling functionality, electrically adjustable lumbar support and adjustable dampers.

7 A set and forget steering wheel makes operator access even easier. It can be instantly returned to, even after you've folded the wheel away.

Specify your 411 or 417 with either air conditioning or automatic climate control to create perfect working temperatures.

With a dedicated media port on board, you can be assured of superb connectivity for all your electronic devices.

A sliding window on both sides of the cab allows easy communication with people outside the machine.

The electronic park brake offers numerous advantages; it's quick and easy to operate, and frees up space to the left side of the operator for extra storage.



5



6



6



7

FULLY SERVICEABLE.

A ONE-PIECE BONNET, EASY GROUND LEVEL ACCESS TO KEY COMPONENTS, LIVELINK TELEMATICS AND WORLD-CLASS AFTERCARE ALL COME AS STANDARD ON THE NEW JCB 411 AND 417, ALL HELPING TO MAXIMISE YOUR UPTIME.

Routine maintenance.

- 1 It's easy to get to the engine on a new JCB 411 and 417 with a large opening single-piece bonnet.
- 2 Accessing the diesel and DEF (Diesel Exhaust Fluid) tanks is also straightforward, via the lockable grille at the rear of the machine. You can also check washer fluid level, engine oil and coolant from inside the cab, with all other routine checks and grease points located at ground level. This makes life both easier and safer.
- 3 The standard widecore cooling package is a large, single-faced unit so you can be assured of quick, easy and safe cleaning.
- 4 With the optional auto lubrication kit, your machine will take care of its own greasing requirements.



Less servicing, more service.

5 The CommandPlus cab relays machine condition giving real time alerts, safeguarding both the machine and operator.

The intuitive CommandPlus “help function” provides the operator with meaningful descriptions of the in- cab switch function. Using the “?” button, this allows new or unfamiliar operators to quickly and easily understand machine functions without having to refer to the operators manual.

6 By using premium components: JCB DieselMAX engine, ZF transmissions and JCB axles, Rexroth pump and Husco valve block, we’ve built in long service life as standard.

Full hydraulic dual circuit braking with multiple oil immersed discs gives the braking system a virtually maintenance-free lifespan.

7 A cyclonic engine fan scavenge filter provides four times the filtering capacity of a standard air filter. Its longer life system has fewer components and a higher level of efficiency, making for better engine protection.

8 Heating and ventilation filters are conveniently located behind an external access panel. The main fuse board and relays have been repositioned next to the door for easy access.

A large 116-litre fuel tank and optional 111 litre auxiliary fuel tank, ensure maximum working hours between refills.



5



6



5

COMMANDPLUS controls.

If you're planning to use your wheel loader in environments with large amounts of airborne debris, opt for the adjustable reversing fan. The fan can be operated via the CommandPlus controls, and even swings out for easy cleaning access.



6



5



5

FULLY PROTECTED.

OPERATORS, BYSTANDERS AND YOUR MACHINERY FLEET ARE WELL PROTECTED AT ALL TIMES BY THE NEW JCB 411 AND 417. GREAT VISIBILITY INSIDE AND OUT, NON-SLIP SURFACES AND EXCELLENT AIR FILTRATION ARE JUST THE BEGINNING.

Safely does it.

1 Access steps on the 411 and 417 are inclined and equally spaced, complemented by well positioned grab handles for three points of contact at all times.

2 On the new JCB 411 and 417, you'll find the rear-view mirrors mounted in front of the B-pillars for improved all-round visibility. Interior mirrors, heated exterior mirrors and bonnet mirrors all combine to offer excellent views to every corner of your machine.

3 Our rear-view camera displays an unobstructed rearward view on the in-cab colour monitor onboard your 411 and 417.

4 Superb visibility in dark conditions is guaranteed with JCB's optional LED lighting.

A green operator presence beacon and hi-viz exterior chevrons are some of the options available to enhance the safety on any worksite.





Safely does it (continued).

5 The new front fender flaps have been carefully designed and honed to keep forward spray to a minimum. This increases safety and decreases debris build-up.

6 Door hinges are mounted on the C-pillar; giving much better access via a larger and wider door aperture. It also means you can access the rear of your loader more safely.

7 Roof mounted camera option provides additional visibility when large capacity attachments are fitted.

8 The new 411 and 417 cabs are isolator-mounted, compliant with ROPS/FOPS standards, and positively pressurised against dust. You can choose from fresh air and carbon recirculation filters as well.

8 New fully customisable automatic worklights engage when reverse is selected. The new headlight assist feature allows operators to automatically turn on the roof worklights for added visibility when working at night.



LIVE JCB LINK



LIVELINK TELEMATICS.

LiveLink telematics helps you monitor and manage your machine fleet remotely anywhere in the world by radically improving the efficiency, productivity, safety and security of all your JCB and non JCB machine fleet.

MACHINE EFFICIENCY: Keep track of your machine's daily activity with regular performance reports which provide information about idle time, location, machine health, error codes for diagnostics, engine utilisation by power band, safety alerts, and fuel consumption. JCB LiveLink ensures machines are kept running for maximum uptime and return on investment.

MACHINE RELIABILITY: Accurate hours and service alerts improve maintenance planning to optimise machine productivity.

MACHINE SECURITY: LiveLink's real time geo-fencing alerts tell you when machines move out of predetermined zones. Curfew alerts inform you of unauthorised usage.



Track the location of any asset via Bluetooth connection.



An after market telematics solution which can be retrofitted to any machine.

LIVE JCB LINK FLEET

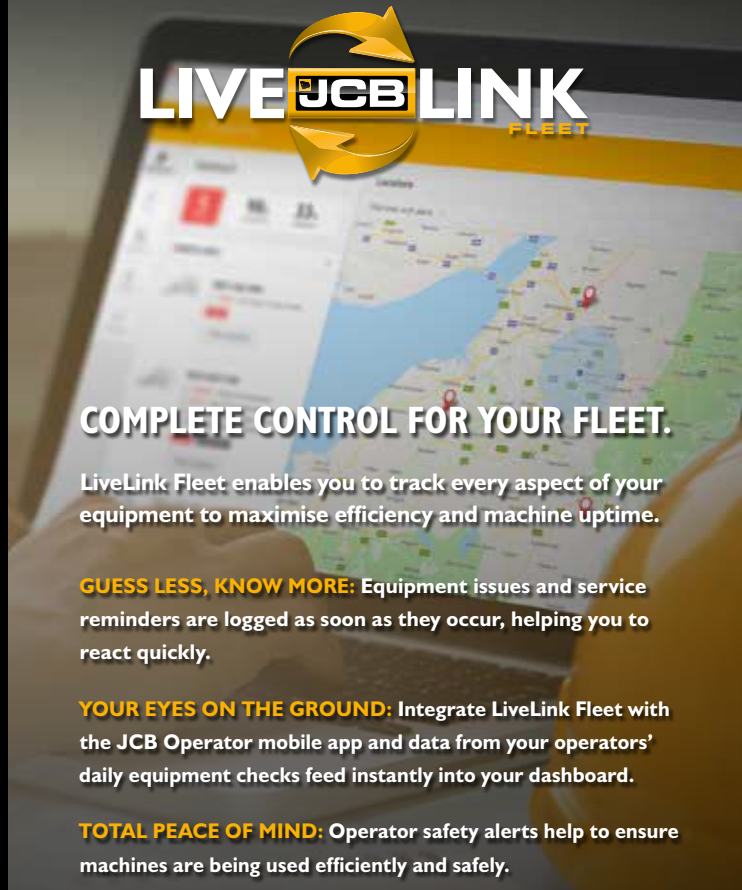

COMPLETE CONTROL FOR YOUR FLEET.

LiveLink Fleet enables you to track every aspect of your equipment to maximise efficiency and machine uptime.

GUESS LESS, KNOW MORE: Equipment issues and service reminders are logged as soon as they occur, helping you to react quickly.

YOUR EYES ON THE GROUND: Integrate LiveLink Fleet with the JCB Operator mobile app and data from your operators' daily equipment checks feed instantly into your dashboard.

TOTAL PEACE OF MIND: Operator safety alerts help to ensure machines are being used efficiently and safely.

SMARTER TOOLS. SMARTER DECISIONS: From hours worked to fuel wastage, access custom analytics on your fleet to make smarter decisions, quicker.

EFFORTLESS MEETS PAPERLESS: Access certificates, warranty information, quick start machine guides and manuals.

The JCB Operator app



THEY SPOT IT, YOU KNOW IT.

The JCB Operator app gives you faster, clearer and more accurate information about your fleet, direct from the people using your equipment each day.

STAY IN TOUCH: Get regular checks on your machine with visibility in the LiveLink Fleet portal.

TAILOR YOUR CHECKS: Customise your checklists to suit any application, customer or site.

UPLOAD TO KEEP UPDATED: Upload useful information with photos and comments.

FULLY COMPATIBLE: The JCB Operator app works with non telemetry related machines and assets.

ACCESS ALL INFORMATION: Get access to documentation such as quick start guides.

*The individual features of LiveLink Telematics, LiveLink Fleet and Operator App vary per region, engine and machine type.

FULLY SUPPORTED.

JCB'S WORLDWIDE CUSTOMER SUPPORT IS FIRST CLASS. WHATEVER YOU NEED AND WHEREVER YOU ARE, WE'LL BE AVAILABLE QUICKLY AND EFFICIENTLY TO HELP MAKE SURE YOUR MACHINERY IS PERFORMING TO ITS FULL POTENTIAL.



1

1 Our Technical Support Service provides instant access to factory expertise, day or night, while our Finance and Insurance teams are always on hand to provide fast, flexible, competitive quotes.

2 The global network of JCB Parts Centres is another model of efficiency; with 18 regional bases, we can deliver around 95% of all parts anywhere in the world within 24 hours. Our genuine JCB parts are designed to work in perfect harmony with your machine for optimum performance and productivity.



3

3 JCB offers comprehensive extended warranties as well as service-only or repair and maintenance contracts. Irrespective of what you opt for, our Maintenance teams around the world charge competitive labour rates, and offer non-obligation quotations as well as fast, efficient insurance repair work.

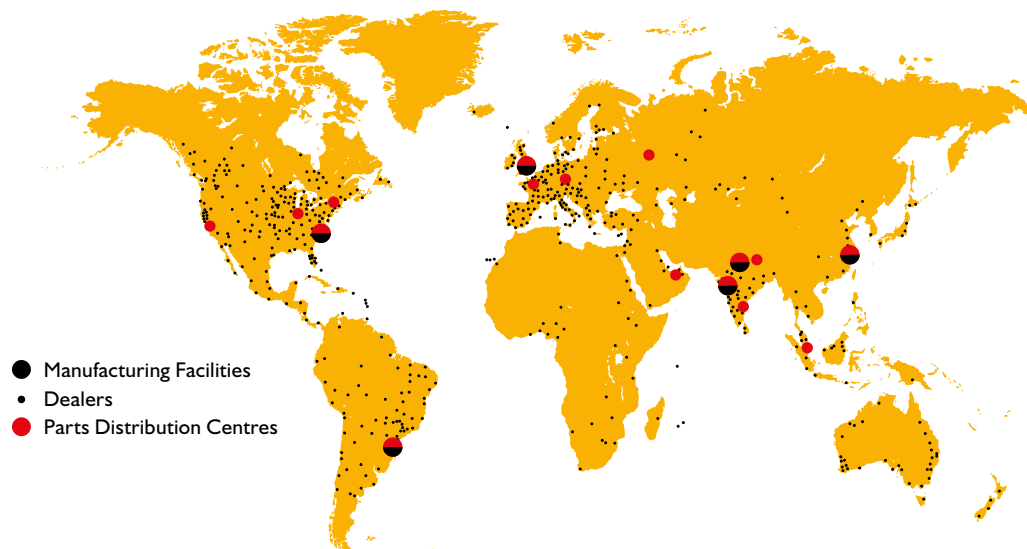

STATIC DIMENSIONS

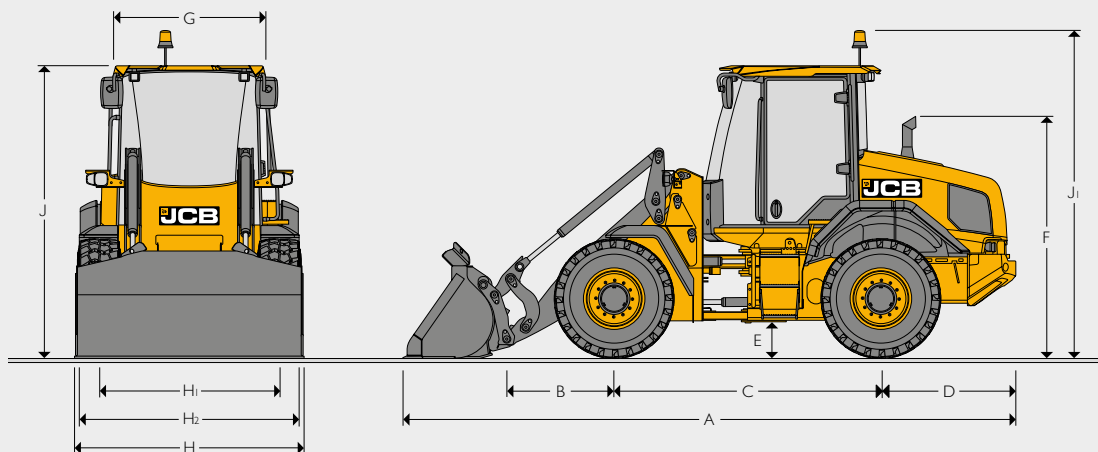

STATIC DIMENSIONS

		411 HT	417 HT	417 HT HL	417 HT SHL	
A	Overall length	mm	6229	6290	6491	7143
B	Axle to pivot pin	mm	1226	1110	1311	1963
C	Wheelbase	mm	2750	2800	2800	2800
D	Axle to counterweight face	mm	1365	1365	1365	1365
E	Minimum ground clearance	mm	344	371	371	371
F	Height over exhaust	mm	2575	2656	2656	2656
G	Width over cab	mm	1431	1431	1431	1431
H	Maximum width over tyres	mm	2204	2339	2339	2339
H1	Wheel track	mm	1800	1880	1880	1880
J	Height over cab	mm	3057	3084	3084	3084
J1	Height over raised beacon	mm	3403	3484	3484	3484
	Front axle weight	kg	3328	3790	3891	4437
	Rear axle weight	kg	5517	5977	5936	5737
	Total weight	kg	8845	9767	9827	10174

411 data based on machine equipped with direct mounted 1.2 m³ bucket with toe plates and Michelin 15.5R25 XHA (L3) tyres.

417 data based on machine equipped with direct mounted 1.6 m³ bucket with toe plates and Michelin 17.5R25 XHA2 (L3) tyres.

TURNING CIRCLE

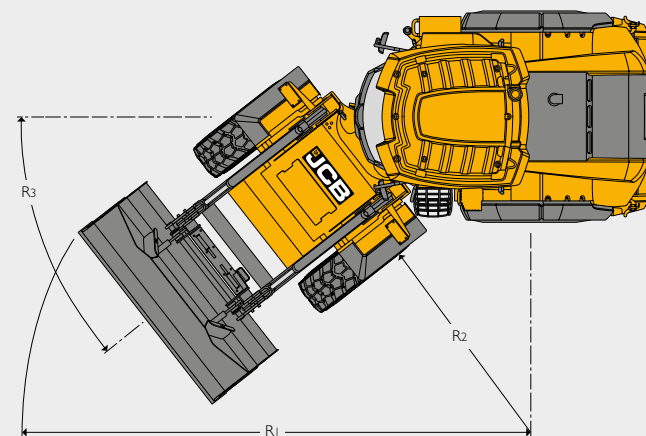

TURNING CIRCLE

			411 HT	417 HT	417 HT HL	417 HT SHL
R1	Max Turn Radius over Shovel	mm	5351	5519	5519	5519
R2	Inside Turn Radius	mm	2658	2705	2705	2705
R3	Articulation Angle	deg	+/-40	+/-40	+/-40	+/-40

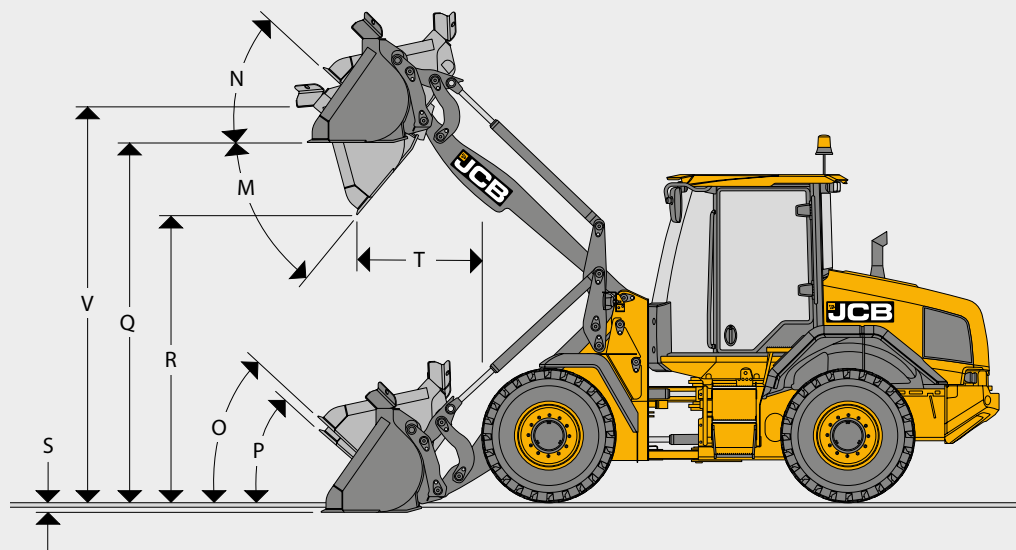

TYRE SIZE 411 HT

Tyre size	Manufacturer	Type	Rating	Operating weight (kg)	HT		Dimensions	
					STL kg	FTTL kg	Vertical mm	Width mm
15.5-25	Goodyear	SGL D/L12 Ply	L2	-132	-88	-75	-9	-5
15.5-25	Goodyear	HRL D/L12 Ply	L3	-60	-40	-34	14	-5
15.5R25	Michelin	XTLA	L2	-44	-29	-25	-2	-7
15.5R25	Michelin	X-MINE D2	L5	640	426	362	54	14
17.5R25	Michelin	SNOPLUS	L2	276	184	156	25	84
17.5R25	Michelin	XTLA	L2	224	149	127	21	95
15.5R25	Nokian	LOADER GRIP 2	L3	-56	-37	-31	3	-10
17.5R25	Nokian	LOADER GRIP	L2	208	138	117	39	81

LOADER DIMENSIONS 411 HT

Model	411 HT										
		Direct					Quickhitch				
		General purpose					General purpose				
Shovel mounting											
Shovel type											
Shovel equipment	Tipped teeth		Reversible toeplate			Tipped teeth		Reversible toeplate			
Shovel capacity (SAE heaped 100%)	m ³	1.2	1.4	1.2	1.4	1.6	1.2	1.4	1.2	1.4	1.6
Shovel capacity (struck)	m ³	1.01	1.18	1.01	1.18	1.36	1.01	1.18	1.01	1.18	1.36
Shovel width	mm	2250	2400	2250	2400	2400	2250	2400	2250	2400	2400
Shovel weight	kg	528	603	528	603	638	505	580	505	580	614
Maximum material density *	kg/m ³	2328	1947	2328	1947	1677	2224	1851	2224	1851	1591
Tipping load straight *	kg	6537	6392	6537	6392	6299	6276	6106	6276	6106	6005
Tipping load full turn *	kg	5585	5451	5585	5451	5366	5337	5182	5337	5182	5091
Payload *	kg	2793	2726	2793	2726	2683	2669	2591	2669	2591	2546
Maximum breakout force	kN	73.2	67.7	73.2	67.7	62.7	67.2	62.3	67.2	62.3	57.1
M Dump angle maximum	degrees	47	47	47	47	47	47	47	47	47	47
N Roll back angle full height	degrees	41	41	41	41	41	41	41	41	41	41
O Roll back at carry	degrees	46	46	46	46	46	46	46	46	46	46
P Roll back at ground level	degrees	42	42	42	42	42	42	42	42	42	42
Q Load over height	mm	3344	3346	3344	3346	3345	3363	3365	3363	3365	3366
R Dump height (45 deg dump)	mm	2780	2718	2780	2718	2668	2749	2687	2749	2687	2638
S Dig depth	mm	132	130	132	130	131	113	113	113	113	113
T Reach at dump height	mm	926	978	926	978	1030	980	1042	980	1042	1084
V Pin height (maximum)	mm	3569	3569	3569	3569	3569	3569	3569	3569	3569	3569
Reach maximum (45 deg dump) horizontal arm	mm	1661	1724	1661	1724	1774	1719	1782	1719	1782	1832
Operating weight (includes 80kg operator and full fuel tank (includes auxiliary tank))	kg	8655	8722	8655	8722	8756	8864	8931	8864	8931	8965

* Assumes machine is fitted with Michelin 15.5R25 XHA tyres.

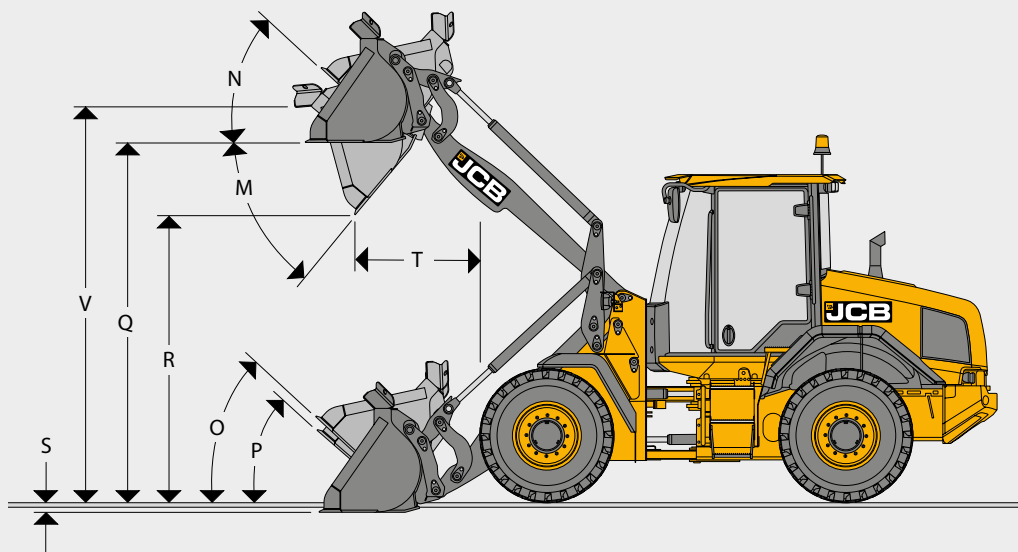

TYRE SIZE 417 HT, HT HL, HT SHL

Tyre size	Manufacturer	Type	Rating	Operating weight (kg)	HT		HT HL		HT SHL		Dimensions	
					STL kg	FTTL kg	STL kg	FTTL kg	STL kg	FTTL kg	Vertical mm	Width mm
17.5-25	Revolution	S2C2		1688	410	349	386	328	314	267	28	12
17.5-25	Revolution	SE		1688	410	349	386	328	314	267	28	12
17.5-25	Goodyear	SGL	L2	-184	-125	-106	-118	-100	-96	-82	2	9
17.5-25	Goodyear	HRL	L3	-52	-35	-30	-33	-28	-27	-23	15	2
17.5-25	Michelin	XTLA	L3	-92	-62	-53	-59	-50	-48	-41	-6	11
17.5-25	Michelin	XSNPLUS	L2	-40	-27	-23	-26	-22	-21	-18	-2	0
17.5-25	Michelin	X-MINE D2	L5	604	410	349	386	328	314	267	59	32
17.5-25	JCB	Earthmover	L3	104	70	60	66	57	54	46	31	-1
500/70R24	Michelin	XMCL		-196	-133	-113	-125	-106	-102	-87	1	163
17.5R25	Nokian	L GRIP	L2	-108	-73	-62	-69	-59	-56	-48	12	-3
17.5R25	BKT	XL GRIP	L3	-68	-46	-39	-43	-37	-35	-30	40	-3
600/55R26.5	Trelleborg	Twin Radial	Radial	140	95	81	90	77	73	62	23	388
20.5-25	Michelin	XHA	L3	504	342	291	324	277	262	223	62	180

LOADER DIMENSIONS 417 HT, HT HL, HT SHL

Model	417 HT								417 HT HL								417 HT SHL							
	Direct				Quickhitch				Direct				Quickhitch				Direct				Quickhitch			
Shovel mounting	General purpose								General purpose								General purpose							
Shovel type	Tipped teeth		Reversible toeplate		Tipped teeth		Reversible toeplate		Tipped teeth		Reversible toeplate		Tipped teeth		Reversible toeplate		Tipped teeth		Reversible toeplate		Tipped teeth		Reversible toeplate	
Shovel equipment																								
Shovel capacity (SAE heaped 100%)	m³	1.4	1.6	1.4	1.6	1.4	1.6	1.4	1.6	1.4	1.6	1.4	1.6	1.4	1.6	1.4	1.6	1.4	1.6	1.4	1.6	1.4	1.6	
Shovel capacity (struck)	m³	1.18	1.36	1.18	1.36	1.18	1.36	1.18	1.36	1.18	1.36	1.18	1.36	1.18	1.36	1.18	1.36	1.18	1.36	1.18	1.36	1.18	1.36	
Shovel width	mm	2400	2400	2400	2400	2400	2400	2400	2400	2400	2400	2400	2400	2400	2400	2400	2400	2400	2400	2400	2400	2400	2400	
Shovel weight	kg	658	698	680	720	643	683	665	705	658	698	680	720	643	683	665	705	658	698	680	720	643	683	
Maximum material density *	kg/m³	2189	1888	2189	1888	2088	1802	2088	1802	2039	1760	2039	1760	1945	1668	1945	1668	1499	1294	1499	1294	1419	1224	
Tipping load straight *	kg	7236	7141	7236	7141	6932	6844	6932	6844	6748	6666	6748	6666	6469	6392	6469	6392	5038	4976	5038	4976	4803	4745	
Tipping load full turn *	kg	6129	6042	6129	6042	5847	5767	5847	5767	5707	5632	5707	5632	5445	5337	5445	5337	4196	4139	4196	4139	3972	3918	
Payload *	kg	3065	3021	3065	3021	2924	2884	2924	2884	2854	2816	2854	2816	2723	2669	2723	2669	2098	2070	2098	2070	1986	1959	
Maximum breakout force	kN	70	64.6	70	64.6	64.9	59.9	64.9	59.9	70	64.6	70	64.6	64.9	59.9	64.9	59.9	70	64.6	70	64.6	64.9	59.9	
M Dump angle maximum	degrees	50	50	50	50	51	50	51	50	47	47	47	47	47	46	47	46	45	45	45	45	45	45	
N Roll back angle full height	degrees	43	43	43	43	43	43	43	43	43	43	43	43	43	43	43	43	47	47	47	47	47	47	
O Roll back at carry	degrees	44	44	44	44	43	43	43	43	43	43	43	43	43	43	43	43	45	45	45	45	45	47	
P Roll back at ground level	degrees	41	41	41	41	41	41	41	41	42	42	42	42	42	42	42	42	44	43	44	43	43	45	
Q Load over height	mm	3341	3343	3341	3343	3339	3358	3339	3358	3559	3554	3559	3554	3568	3567	3568	3567	4202	4199	4202	4199	4216	4216	
R Dump height (45 deg dump)	mm	2714	2666	2714	2666	2661	2631	2661	2631	2930	2878	2930	2878	2890	2839	2890	2839	3575	3522	3575	3522	3538	3488	
S Dig depth	mm	110	109	110	109	92	92	92	92	116	111	116	111	96	96	96	96	148	152	148	152	132	132	
T Reach at dump height	mm	930	973	930	973	993	1031	993	1031	986	1034	986	1034	1046	1097	1046	1097	1074	1122	1074	1122	1130	1180	
V Pin height (maximum)	mm	3566	3566	3566	3566	3566	3566	3566	3566	3946	3946	3946	3946	3946	3946	3946	3946	4411	4411	4411	4411	4411	4411	
Reach maximum (45 deg dump) horizontal arm	mm	1639	1688	1639	1688	1697	1746	1697	1746	1790	1839	1790	1839	1848	1897	1848	1897	2319	2369	2319	2369	2377	2427	
Operating weight (includes 80kg operator and full fuel tank (includes auxiliary tank))	kg	9567	9602	9567	9602	9777	9812	9777	9812	9617	9652	9617	9652	9827	9862	9827	9862	9907	9942	9907	9942	10117	10452	

* Assumes machine is fitted with Michelin 17.5 R25 XHA tyres.

LOADER DIMENSIONS – FORK FRAME WITH FORKS

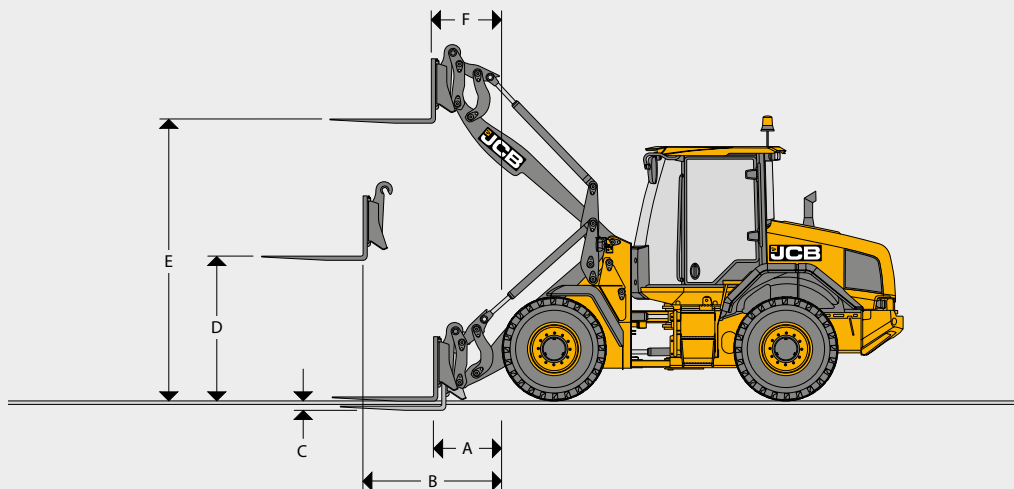

LOADER DIMENSIONS – FORK FRAME WITH FORKS

		Parallel fork				Non parallel fork			
		411 HT	417 HT	417 HT HL	417 HT SHL	411 HT	417 HT	417 HT HL	417 HT SHL
Fork carriage width	mm	1500	1500	1500	1500	1500	1500	1500	1500
Length of tines	mm	1220	1220	1220	1220	1220	1220	1220	1220
A Reach at ground level	mm	924	787	969	1620	923	785	984	1631
B Reach at arms horizontal	mm	1527	1459	1590	2115	1512	1447	1596	2118
C Below ground level	mm	78	57	55	79	62	68	64	88
D Arms, horizontal height	mm	1671	1745	1744	1744	1626	1735	1735	1735
E Arms, maximum height	mm	3395	3395	3618	4267	3414	3385	3599	4257
F Reach at maximum height	mm	823	829	806	846	776	817	819	853
Payload*	kg	3360	3722	3482	2630	3477	3714	3466	2622
Tipping load straight	kg	4948	5480	5172	3977	5093	5505	5150	3965
Tipping load full turn (40°)	kg	4200	4653	4353	3288	4346	4642	4333	3278
Attachment weight	kg	435	435	435	435	430	430	430	430

Assumes the fitment of Michelin 15.5R25 XHLA (L3) tyres for 411 and Michelin 17.5R25 XHA (L3) tyres for 417.

Manual fork spacing's at 50mm increments. Fork section 100mm x 50mm.

* At the centre of gravity distance 500mm. Based on 80% of FTTL as defined in ISO 8313.

BUCKET SELECTOR

Material	Loose density (kg/m³)	Fill factor (%)
Snow (fresh)	200	110
Peat (dry)	400	100
Sugar beet	530	100
Coke (loose)	570	85
Barley	600	85
Petroleum coke	680	85
Wheat	730	85
Coal bituminous	765	100
Fertiliser (mixed)	1030	85
Coal anthracite	1046	100
Earth (dry) (loose)	1150	100
Nitrate fertiliser	1250	85
Sodium chloride (dry) (salt)	1300	85
Cement Portland	1440	100
Limestone (crushed)	1530	100
Sand (dry)	1550	100
Asphalt	1600	100
Gravel (dry)	1650	85
Clay (wet)	1680	110
Sand (wet)	1890	110
Fire clay	2080	100
Copper (concentrate)	2300	85
Slate	2800	100
Magnetite	3204	100

411 - HT

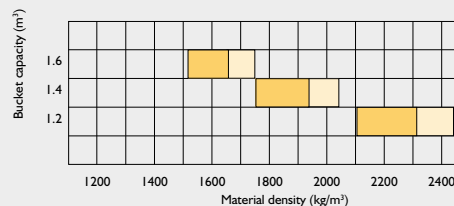

417 - HT

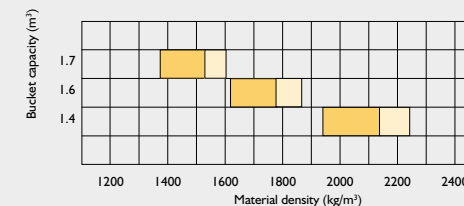

417 - HT HL

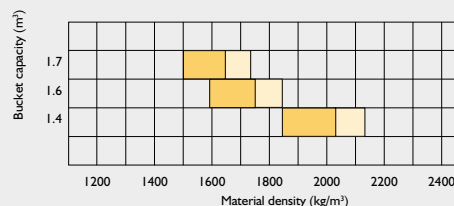

417 - HT SHL

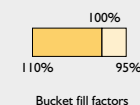
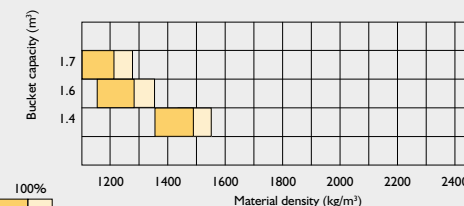

ENGINE			
		411	417
Manufacturer			
Model		JCB DieselMax	JCB DieselMax
Capacity	litres	4.8	4.8
Cylinders		4	4
Bore	mm	106	106
Stroke	mm	139	139
Aspiration		Turbo charged	Turbo charged
Max Power	kW (hp) @ 2200 rpm	81 (109)	97 (130)
Rated Power	kW (hp) @ 2200 rpm	81 (109)	97 (130)
Power @ Max Torque	kW (hp) @ 1500 rpm	78.4 (105)	88 (118)
Max Torque	Nm	516@1450	550@1500
Valves per cylinder		4	4
Air cleaner		Cyclonic Pre filter	Cyclonic Pre filter
Fan drive type		Standard: Viscous Drive Fan Option: Hydraulic (Auto Reverse)	Standard: Viscous Drive Fan Option: Hydraulic (Auto Reverse)
Emissions		Stage V	Stage V

TRANSMISSION					
		411		417	
		Smooth shift Powershift			
Type / Model		ZF 4WG115			
Torque convertor stall ration		3.01:1		2.3:1	
		Forward	Reverse	Forward	Reverse
40kph					
1 st gear	kph	5.5	5.8	5.4	5.7
2 nd gear	kph	13	13.7	12.8	13.5
3 rd gear	kph	28.8	30.1	28.4	29.8
4 th gear	kph	40	-	40	-

LOADER HYDRAULICS			
		411	417
Pump type		Double gear pump	Variable placement piston pump
Pump 1 maximum flow	l/min	50.6	156
Pump 1 maximum pressure	bar	220	240
Pump 2 maximum flow	l/min	72.6	-
Pump 2 maximum pressure	bar	230	-
Hydraulic cycle times at full engine revs		411	417
Arms raise (full bucket)	Seconds	5.0	4.9
Bucket dump (full bucket)	Seconds	1.1	2.1
Arms lower (empty bucket)	Seconds	3.7	3.3
Total cycle	Seconds	9.8	10.3

AXLES			
411			
Type		Epicyclic hub reduction	
Make & model	Standard fit	JCB PD70 (front & rear)	
Overall axle ratio 40kph		18.16:1	
Rear axle oscillation		± 11°	
417			
Type		Epicyclic hub reduction	
Make & model	Standard fit	JCB PD87 (front & rear)	
Overall axle ratio 40kph		20.18:1	
Rear axle oscillation		± 11°	

STEERING	Hydraulic power steering system with emergency steering.
BRAKES	Hydraulic power braking on all wheels. In board mounted, oil immersed, multi-plate disc brakes. Mechanically or Electro-Hydraulically activated disc type parking brake operating on transmission output shaft.
CAB	In-cab noise level – 68dB(A). External Noise 103dB(A).

ELECTRICAL SYSTEM			
		411	417
System voltage	Volt	24	
Alternator output	Amp hour	100	
Battery capacity	Amp hour	2 x 110	

SERVICE FILL CAPACITIES			
		411	417
Hydraulic system	litres	155	
Fuel tank	litres	116	
Auxiliary fuel tank	litres	111	
DEF	litres	20	

NOISE AND VIBRATION					
		Uncertainty		Measurement conditions.	
Noise at the operator station	LpA	68 dB	+/- 1 dB	Determined in accordance with the test method defined in ISO 6396 and the dynamic test condition defined on 2000/14/EC.	
Noise emission from the machine	LWA	103 dB	+/- 1 dB	Guaranteed equivalent sound power (external noise) determined in accordance with the dynamic test conditions defined in 2000/14/EC.	
Whole body vibration	m/s ²	0.58	+/- 0.11 dB	ISO 2632-1:1997 normalised to an 8h reference period and based upon a test cycle comprising of loader work (soil).	
Hand-arm vibration	m/s ²	<2.5	N/A	ISO 5349-2:2001 dynamic test conditions.	

EQUIPMENT

SERVICE AND MAINTENANCE

5 year LiveLink telematics	•
Engine oil remote drain and fill	•
Grouped pressure test points	•
Lockable tool box	•
Lubrication points accessible from ground level	•
Transmission oil level sight gauge	•
Hydraulic level sight gauge	•

ENGINE

Air cleaner – cyclonic pre-filter with engine fan scavenge system	•
Fixed viscous mounted fan	•
Automatically reversing cooling fan	+
Crankcase breather oil trap	•
DEF fluid	•
Epoxy coated radiator / coolers	+
Fuel filter	•
Fuel pre-filter with water trap	•
Hydraulically driven cooling fan	•
-20° cold start	•
DPF / SCR engine emission control	•
Waste gated turbo	•
Widcore radiator	•
Auto engine idle shut down timer (in cab adjustable)	•

ELECTRICAL

100 amp alternator	•
Amber rotating beacon	•
Green seatbelt beacon	+
Electrical adjustable mirrors	•
Heated mirrors	•
External battery isolator	•
Fold down beacon arm	•
Halogen front and rear working lights	•
Full road light kit	•
Integrated rear view camera	+
LED front and rear working lights	+
LED 360° work lights	+
Number plate light kit	+
Radio wiring and speakers	•
Reverse alarm	•
Smart reverse alarm	+
White noise reverse alarm and light	+

DRIVE TRAIN

4 speed transmission 20kph	+
4 speed transmission 40kph	+
Gear kick down on loader control lever	•
Loader lever direction control	•
Neutral start	•
Open differential	•
Limited slip differentials front and rear	+
Oscillating rear axle	•
Foot brake operated transmission disconnect (selectable)	•
Selectable automatic powershift	•
Speed limiter 20kph	+
Steering column single lever shift control (direction and gear)	•
Transmission cooler bypass	+

BRAKE SYSTEM

Multi-plate wet disc brakes	•
Parking disc brake on transmission output shaft	•
Mechanical hand operated park brake	•
Electrical hydraulic park brake	+
Independent accumulator backup for electric park brake	+

OPERATOR STATION

Fully glazed cab	•
Front windscreen guards	+
Air conditioning	•
Climate control	+
Single lever joystick	•
Multi-lever hydraulic controls	+
Proportional electro-hydraulic auxiliary control	+
Electronic adjustment of SRS (Smooth Ride System) cut-in speed	+
Electronic adjustment of reverse fan interval	+
Air suspension cloth seat	•
Deluxe heated air suspension cloth seat	+
Super deluxe heated & cooled air suspension half leather seat	+
Front roller blind	•
Rear roller blind	+
Cab air intake filter	•
Carbon cab air intake filter	+
12V in cab power socket	•
2 x 12V in cab power socket	+
24V in cab power socket	+
Reversing camera (colour)	+
Fold away adjustable steering column	•
ROPS / FOPS safety structure	•
Interior light	•

OPERATOR STATION (CONTINUED)

Front primary display screen	•
Secondary A post display screen, rotary control menu interface	+
A post mounted membrane switches	•
50 mm seatbelt	•
75 mm seatbelt	+
Fire extinguisher (UK & USA only)	+
Two speed intermittent front windscreen wipe / wash and self-park	•
Single speed rear windscreen wipe/wash and self-park	•
3 speed heater/demisting	•
LH and RH sliding opening windows	•
Floor mat	•
Cup holder	•
Steering wheel spinner knob	•
Internal rear view mirror	•
Tinted cab glass	•
Multimedia port (USB and 3.5mm)	+
Operator stowage	•
Laminated windscreen	•
Heated rear screen	•
Loader control isolator	•
Horn	•
Adjustable armrest	•
Removable storage rubber mats	•

FRONT PRIMARY DISPLAY

Warning lights

Direction indicators	•
Master warning	•
High coolant temperature	•
Battery charging condition	•
Low fuel level	•
Engine oil pressure	•
Hazard lamps	•
Park brake state	•
Road lights	•
Main beam lights	•
Rear fog lights	•
Engine pre-heat	•
Brake system pressure	•
Low steering pressure	•

Buzzer alerts

Engine air filter blocked	•
Diesel exhaust fluid (DEF)	•
Torque reduction in case of malfunction	•
Amber warning lamp	•

EQUIPMENT

FRONT PRIMARY DISPLAY (CONTINUED)

Guage display	
Engine speed	•
Coolant temperature	•
Fuel level	•
LCD screen display	
Current gear	•
Torque reduction in case of malfunction	•
Amber warning lamp	•
Diesel exhaust fluid (DEF)	•
Secondary steer system pressure	•
Steer mode	•
Ground speed	•
Engine Speed (numeric display)	•
Clock	•
Hydraulic state	•
SRS (Smooth Ride System)	+
Beacon	•
Front work lamps	•
Rear work lamps	•
Heated rear screen	•
Transmission sump temperature	•
Data screens	
DEF level	•
Hydraulic oil temperature	•
Torque convertor temperature	•
Volume of fuel remaining	•
Total fuel used (resettable)	•
Instantaneous fuel use	•
Average fuel use (resettable)	•
Current date	•
Machine hours	•
Trip distance (resettable)	•
Hours to service	•
Daily checks	•
Engine oil level	•
DEF level	•
RIGHT HAND SECONDARY DISPLAY - OPTIONAL	
Clock	•
Climate control	•
Fan speed	•
In-cab temperature set	•
Machine hours	•
Rear view camera	•
Fuel use	•

RIGHT HAND SECONDARY DISPLAY - OPTIONAL (CONTINUED)

Time and date	•
Auxiliary flow rate	+
Hydraulic oil temperature	•
Transmission oil temperature	•
Machine settings screen	
Coolant temperature	•
Engine oil pressure	•
Air filter	•
Transmission sump temperature	•
Transmission torque convertor temperature	•
Hydraulic oil temperature	•
Battery voltage	•
Help display	•
On-screen handbook	•
HYDRAULIC SYSTEM	
Smoothride system (SRS)	+
Hydraulic quickhitch with in-cab isolation	+
Auxiliary ARV kit	+
Auxiliary hydraulic service	+
Twin auxiliary hydraulic service	+
Emergency steer back-up	•
JCB biodegradable hydraulic oil	+
Electronic hydraulic isolation	•
Automatic boom kick-out. Detent	•
Automatic bucket positioner	•
Front loader float	•
Hydraulic oil cooler	•
EXTERNAL EQUIPMENT	
Front and rear fenders	•
Front adjustable mud flaps	•
Front wheel spray guards	•
Automatic greasing system	+
Grease gun and cartridge	+
Mesh air intake screens	•
Flexible bottom step	•
Full width rear counterweight	•
Chevron rear counterweight	+
Recovery hitch	•
Lifting / tie down lugs	•
Auxiliary fuel tank	+

PROTECTIVE EQUIPMENT

Front cab screen guards	+
Wastemaster package: includes front and rear light guards, front screen guard, Wastemaster decal.	+
Rear grille guard	+
Loader arm safety strut	•
Light guards	+
Belly guard kit	•
Articulation joint safety strut	•

OTHER EQUIPMENT

High lift loader end (417 only)	+
Super high lift loader end (417 only)	+

STANDARD •

OPTIONAL +









ONE COMPANY, OVER 300 MACHINES.

Your nearest JCB dealer

Wheel Loader 411/417

411/417 – Operating weight: 8722kg/9602kg Gross engine power: 81kW (109hp)/97kW (130hp)
 Full turn tipping load: 5451 kg/6042kg Standard shovel capacity: 1.4m³/1.6m³

JCB Sales Limited, Rocester, Staffordshire, United Kingdom ST14 5JP.
 Tel: +44 (0)1889 590312 Email: salesinfo@jcb.com
 Download the very latest information on this product range at: www.jcb.com

©2021 JCB Sales. All rights reserved. No part of this publication may be reproduced, stored in a retrieval system, or transmitted in any form or by any other means, electronic, mechanical, photocopying or otherwise, without prior permission from JCB Sales. All references in this publication to operating weights, sizes, capacities and other performance measurements are provided for guidance only and may vary dependant upon the exact specification of machine. They should not therefore be relied upon in relation to suitability for a particular application. Guidance and advice should always be sought from your JCB Dealer. JCB reserves the right to change specifications without notice. Illustrations and specifications shown may include optional equipment and accessories. The JCB logo is a registered trademark of J C Bamford Excavators Ltd.

