



**AMAZONE**

Mounted spreader **ZA-TS**



**AMAZONE spreaders  
meet all European  
environmental  
standards**

# ZA-TS mounted spreader

The high output spreaders from AMAZONE



❗ “If everything is adjusted correctly, then one doesn’t need to worry about anything.”  
(profi – Spreading systems in practice “hydraulic or mechanical” · 06/2017)

❗ “The application rate of the weigh cell spreader was always correct. We also liked the lateral and longitudinal distribution.”  
(dlz agrar magazine – Long term test ZA-TS “Wide throwing master” · 01/2016)

The ZA-TS mounted spreader is available with hopper capacities from 1,400 to 4,200 l. The TS spreading unit enables working widths of up to 54 m along with excellent border spread patterns, making the ISOBUS ZA-TS mounted spreader one of the absolute high output spreaders.

The reliable weighing system, its precise border spreading system, together with the new BorderTS border spreading system alongside the innovative WindControl and Argus Twin systems put this fertiliser spreader in a class of its own.



# ZA-TS

## precise – quick - comfortable

	Page
The advantages at a glance	4
High-quality, multi-layer paint	6
Frame and hopper   Extensions	8
Profis weighing system   Tilt sensor	10
ProfisPro weighing system	12
FlowCheck   Low level sensors   Spreading disc drive	14
Soft Ballistic System pro	16
TS spreading unit   Agitator	18
Delivery and spreading system   Metering aperture   Setting motors	20
TS spreading discs   Normal spreading	22
Border spreading systems   Border spreading	24
AutoTS	26
BorderTS border spreading process	28
Innovation Farm field trial	30
HeadlandControl	32
WindControl	34
ArgusTwin	36
Optional equipment	38
Front-mounted spreader	41
ZA-TS model overview	42
ISOBUS	44
Spreader Application Center   mySpreader App	54
Technical data	56

! “Anyone who operates in sloping terrain or that has to struggle against heavily deviating fertiliser properties, or on very large working widths with poor throwing fertilisers, will be grateful for this new precision.”

(dlz agrar magazine – Long term test ZA-TS 3200 Profis Hydro · 02/2017)

# ZA-TS mounted spreader

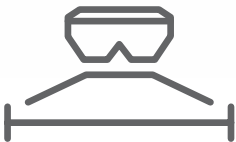

15 m – 54 m



1,400 l – 4,200 l



8 to 128 part-width sections



Mechanical or hydraulic

# The advantages at a glance:

- ⊕ WindControl (in accordance with Prof. Dr. Karl Wild, HTW Dresden) for permanent monitoring and automatic compensation for the effects of the wind on the spread pattern
- ⊕ Automatic adjustment of the lateral distribution via ArgusTwin – possibly the most comfortable way of spreading fertiliser
- ⊕ ProfisPro weighing system - the perfect combination of the Profis weighing system and the FlowControl torque measuring system
- ⊕ Precise border fertiliser application, right up to the field boundary with the BorderTS in combination with the disc-integrated, Auto TS border spreading system.
- ⊕ HeadlandControl for optimum lateral distribution and uniform crops across the headland
- ⊕ Maximum work rates with application rates of 650 kg/min and operational speeds of up to 30 km/h

## MORE INFORMATION

[www.amazone.net/za-ts](http://www.amazone.net/za-ts)



**PRODUCT FILM**  
Find out more



**DOWNLOADS**  
mySpreader App



**SMARTLEARNING**  
[www.amazone.net/smartlearning](http://www.amazone.net/smartlearning)

# The best of both worlds

Cathodic dip painting (CDP) combined with powder coating

**7 years**  
guarantee

against perforation corrosion



register  
enregistrer  
registrieren



The new paint system, in combination with the use of largely stainless steel components provides high levels of availability and durability, rounded off by the use of impact-resistant and UV-resistant plastic sieves.



The KTL dip-paint priming of all components ensures virtually full-area corrosion protection.



Double protection through the additional thick powder coating, providing increased protection against mechanical wear and tear.

## High-quality, multi-layer paint

The paintwork on a fertiliser spreader is exposed to particular demands. The paintwork is intended to protect the spreader from corrosion, especially when handling fertiliser and where moisture is involved. Starting with the 2022 model year, there is a new painting process for the ZA-V, ZA-TS and ZG-TS fertiliser spreader ranges.

This involves, on the one hand, a cathodic dip painting process (known as KTL) for priming to give the best possible protection on the internal surfaces of tubes and box sections and, on the other hand, a powder coating process to create a high-quality visual finish with extra-thick paint providing increased protection against mechanical demands.

## 7 year manufacturer guarantee

Based on this optimum painting process, AMAZONE is able to offer its customers a manufacturer guarantee of seven years against rusting through, starting with the 2022 model year. From 01/01/2023, customers can apply to have the guarantee activated for ZA-V, ZA-TS, and ZG-TS models,

starting from the 2022 model year. This registration is done very simply via the manufacturer's portal, myAmazone, bearing in mind the terms and conditions ([www.amazone.net/7-years](http://www.amazone.net/7-years)) stated there. After registration, one can continue to work without any worries.

## The benefits

- ✔ **Cathodic dip painting process**
  - Suppression of rust infiltration
  - Best possible protection, even on the inner surfaces of tubes and box sections
- ✔ **Powder coated top coat**
  - Double protection through additionally applied powder coating
  - Improved resistance against everyday wear and tear
- ✔ **Quality and reliability**
  - All the components on the spreading unit and all the hydraulic fittings are made of stainless steel
  - Impact, UV and chemical resistant plastic sieves

## High-quality multi-layer paint finish - the most modern from all angles:

- ① 14-stage **painting preparation** (e.g. degreasing)
- ② **Zinc phosphating** provides the most effective counteraction of rust formation
- ③ **Thick cathodic dip priming** for full corrosion protection, even in cavities and those hard-to-reach areas
- ④ **Powder coating** for a high-quality appearance and extra thick paint for increased protection against mechanical demands



The combination of tried and tested painting techniques unites the best from all areas, resulting in a high-quality multi-layer paint finish

# Frame and hopper

Strength pays dividends



ZA-TS 2000 Profis Tronic

## Outstanding design: mounted spreader with 4,500 kg payload.

### The benefits

- ✔ lightweight frame design with excellent rigidity
- ✔ optimised centre of gravity and yet plenty of space for hitching up

- ❗ “For Amazone, their payload of up to 4.5 t is the highest.”  
(profi – Practice test “Four fertiliser spreaders in comparison” · 01/2016)

## The frames

- ✔ **Super frame:** 3,200 kg payload, Cat. II linkage dimensions and fixing pins.
- ✔ **Ultra frame:** 4,500 kg payload, Cat. III linkage dimensions and Cat. II/III fixing pins.

## The deep-drawn hopper

The basic hopper has a capacity of 700 l. It is a deep-drawn meaning that it does not have any corners, edges, and welded seams. This ensures a continuous and even flow of fertiliser. Also the cleaning of the spreader is made easy thanks to this design.



## The benefits of the design

- ✔ No corners and edges
- ✔ Even and constant flow of the fertiliser
- ✔ Less danger of bridging
- ✔ Corrosion resistant
- ✔ Simple cleaning procedure

### ✔ Quick Hitch Adapter

Mounted spreaders with Ultra or Ultra Profis frames for a payload up to 4,500 kg can also be mounted on the tractor using the Quick Hitch quick-coupling system. This involves replacing the 3-point mounting frame by a Quick Hitch Adapter.





# The extensions

In two widths and many sizes

**The wide ones**  
with a filling width of 2.71 m  
and folding ladders



L 2200 extension

**The narrow ones**  
with a filling width of 2.22 m



S 1400 extension S 1700 extension



L 2700 extension



S 2000 extension



L 3200 extension



S 2600 extension with foldable ladder



L 4200 extension

## Additional bolt-on extensions

For a subsequent increase in hopper capacity for the ZA-TS, AMAZONE offers for both the S and L base machines a suitable bolt-on extension.

The volume of the extension is 600 l for S hoppers and 800 l for L hoppers.

- ✔ Direct filling from a tipping trailer or big bags is no problem. Especially when using large loading shovels the wide L extension is of major benefit.

ZA-TS with L 800 hopper extension



# Profis weighing system

He who weighs wins!



-  Filling aid in combination with the Profis weighing system  
 Flashing followed by the constant lighting up of the work lights signals that the fill level has been reached.

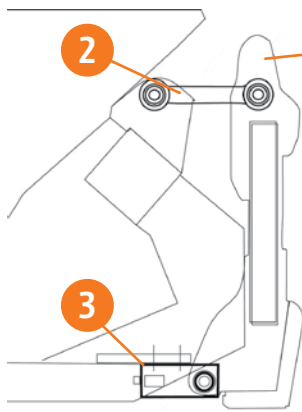

- ① Weighing frame
- ② Horizontally aligned tie rods
- ③ Weigh cells



✔ Compact tractor mounting

## No calibration. Top up the spreader hopper up and off we go! There is nothing simpler.

The weighing system offers controlled convenience and more reliability. It enables on-line determination of the different spreading material properties with two 200 Hz load cells – providing a high level of measuring accuracy. It automatically compares the actually applied rate with the pre-determined rate. Deviations in the flow characteristics, for example when spreading blended mineral fertilisers,

are detected and the spreader is re-adjusted automatically via the electric metering shutter slides. In addition, for field-related nutrient application, for example, the applied rate is precisely documented. In addition, the application rate can be altered at any time by pressing a button on the ISOBUS terminal.

## Tilt sensor for heavily undulating terrain

On the Profis system, any possible effects of gravity on the measuring of the hopper contents are taken into account during work with the help of a tilt sensor: A twin-axis tilt sensor that assesses the front and back tilt as well as to the left and right, corrects measurement errors that may arise when going up and down hills or when driving across a hillside.

## The benefits

### Regulating/calibrating under all operating conditions:

- ✔ Side, border and water course spreading
- ✔ Spreading in wedge-shaped fields
- ✔ Using application maps/N-sensors

### Absolute weight assessment:

- ✔ Residual volume display
- ✔ Residual area and residual width display
- ✔ Documentation of the total volume spread

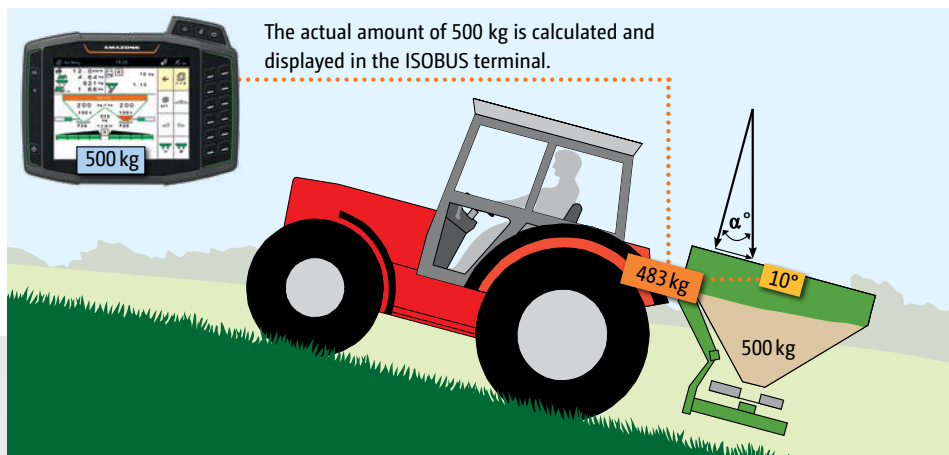

### Example:

- The tilt sensor records the inclination of 10°
- The weigh cell on the ZA-TS Profis records 483 kg

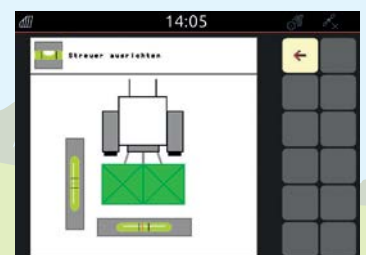

- ✔ For simplifying the mounting of the ZA-TS onto the tractor in the horizontal position, the angle of the ZA-TS Profis is comfortably displayed in the ISOBUS terminal.

# ProfisPro weighing system with torque measuring

The ProfisPro intelligent weighing system combines the benefits of the weighing system with the FlowControl torque measuring system

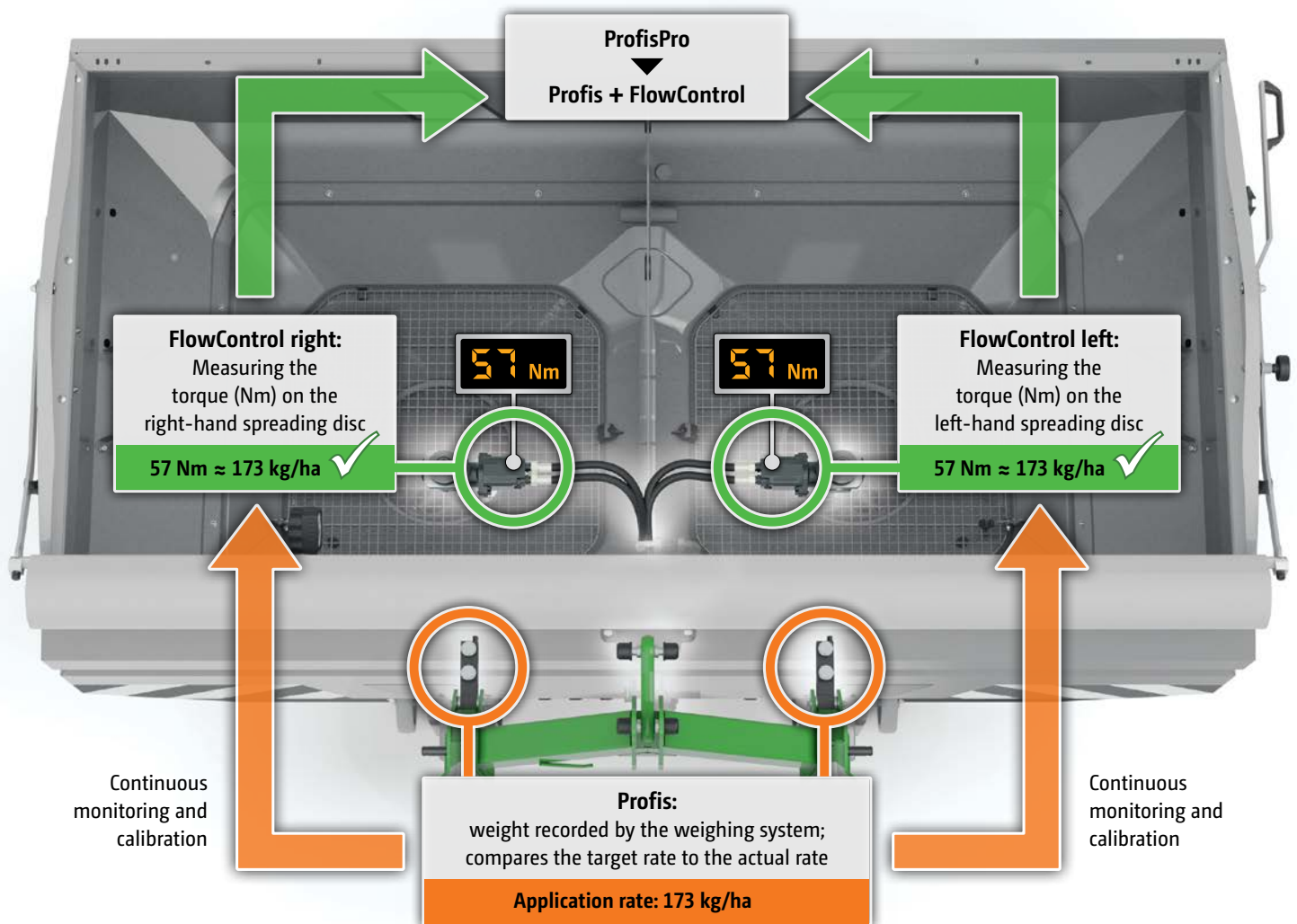

## ✓ ProfisPro

The spread rate regulation between the Profis weighing system and the FlowControl sensors is a unique selling feature for AMAZONE.

## ✓ ProfisPro for Tronic and Hydro

The intelligent ProfisPro weighing system is available for both the Tronic version with mechanical drive, and the Hydro version with hydraulic drive.



Precise application rate from the very first second with ProfisPro

## New rate calibration completely thought through: ProfisPro

The correlation between application rates and the torque generated at the spreading disc at different working widths has been determined for all types of fertiliser on the basis of numerous spreading tests. Put simply: Low application rates generate less torque on the disc than higher rates.

FlowControl reliably monitors the torque on each spreading disc drive independently and can immediately adjust the position of the application rate shutters in the event of a deviation from the target rate.

## Optimised spread rate from the very first second

This combination of weighing system and FlowControl enables the fertiliser spreader to use torque in order to regulate its theoretical application rate over the complete spreading process. The Profis weighing system monitors the actual spread rate every 25 kg. This allows FlowControl to recalibrate itself at regular intervals. This takes place without any need to stop. The ProfisPro intelligent weighing system means that the spread rate is optimised from the very first second of the spreading process.

In addition, the driver has an overview of the actual quantity remaining in the hopper at all times as well as the possibility to display the remaining travelling distance until empty.

## The benefits

### The right process for all conditions:

- ✔ rate calibration irrespective of which side
- ✔ absolute precision from the very first second
- ✔ detection of empty runs and blockages
- ✔ double security as a result of mutual monitoring of both systems

# Reliable to the last detail

## FlowCheck for monitoring the shutter apertures

AMAZONE offers the FlowCheck monitoring device for the ZA-TS Hydro series as an inexpensive alternative to FlowControl.

Whereas FlowControl can control and adjust the application rate independently to each side, FlowCheck only detects blockages and when one of the two shutter apertures is running empty. Should a blockage occur, both systems rectify the fault by quickly opening and closing the shutter slide whilst simultaneously reversing the agitator. This means absolute reliability of operation for the farmer.



✔ FlowCheck sensors in the hydraulic circuit

## Low level sensors

When spreading on slopes, or when border spreading, it can happen that one hopper tip empties quicker than the other. In order to check each outlet apertures individually, AMAZONE therefore additionally offers low level hopper sensors. With a premature emptying of one side, the relevant hopper tip is indicated in red in the operator terminal so that the driver is warned early enough.



✔ Low level sensor for the ZA-TS  
The driver receives a warning message early enough when either hopper tip is almost empty.

# The spreading disc drive

Mechanical or hydraulic, choose for yourself!

## Tronic – mechanical spreading disc drive

The spreading unit is driven via the PTO shaft on the Tronic version. In this case, the spreader is protected from overload, as standard, by a universal drive shaft with friction coupling. The input speed from the tractor PTO is transmitted via the central gearbox resulting in an increased spreading disc speed. This allows fertilisation at low engine revs across the maximum working width.

With the mechanically-driven spreaders, either 8 or 16 part-width sections are switchable, depending on the operator terminal.



✔ ZA-TS-Tronic – mechanical spreading disc drive

## Hydro – hydraulic spreading disc drive

The Hydro version makes operation possible irrespective of the tractor's engine revs and with different spreading disc speeds. In this way, fuel is saved and a particularly comfortable and precise spreading is ensured. The spreader also operates at various different spreading disc speeds in border spreading, so that the best-possible lateral distribution can be achieved in the overlap area and in the field boundary.

- ✔ The side-independent regulation of the spreading disc speed permits even more precise spreading on wedge-shaped fields. Up to 128 part-width sections are possible in combination with Section Control.
- ✔ With a pressure filter as standard



✔ ZA-TS- Hydro – hydraulic spreading disc drive

# Soft Ballistic System pro

For an even gentler fertiliser treatment



## 4 decisive advantages with SBS pro

Mineral fertiliser needs to be gently handled to ensure a precise distribution and an exact placement to the plant over the entire working width. Fertiliser, which has been damaged whilst going through the spreader, will not be precisely distributed.

As a safety feature, AMAZONE Soft Ballistic System pro is integrated as standard. The agitator, metering components and spreading discs are optimally tailored to each other. This protects the fertiliser and secures your yields.

### 1. Gentle guidance

The electrically-driven star agitators in the hopper bottoms ensure an even fertiliser flow onto the spreading discs. The slowly rotating, star shaped segments of the agitator evenly deliver the fertiliser to the relevant outlet opening. When the delivery system is adjusted, the agitator star rotates as well so that it is always perfectly positioned above the aperture. The agitator switches off automatically when the shutter slide is closed.

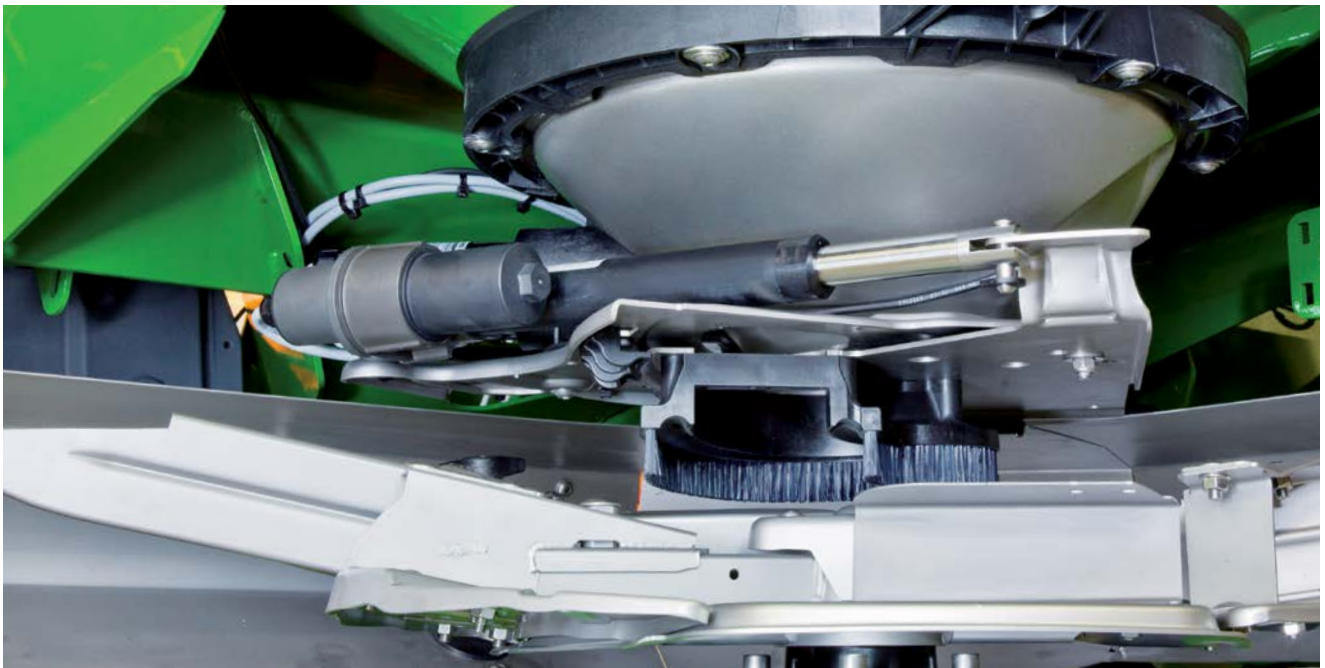

✔ Spreading system with delivery system, brush kit and spreading disc





## 2. Gentle delivery

Due to the delivery system, adjustment to the throwing width and throwing direction can be regulated. In addition, the working width can be adjusted each side individually by changing the disc speed. The fertiliser is fed on centrally at a low peripheral speed resulting in little fertiliser damage. The concentric delivery system adjustment results always in a gentle treatment of the fertiliser.

## 3. Gentle acceleration

With a standard disc speed from 600 rpm up to 900 rpm, the AMAZONE's Soft Ballistic System pro gently accelerates the fertiliser. Even fertiliser types with minimal breaking strength maintain their spreading properties and provide a clean, even spread pattern.

## 4. Gentle ejection

With the AMAZONE Soft Ballistic System pro, as little energy as possible is given to the fertiliser for an optimum trajectory and a precise spread pattern. So, the spreading vanes are optimally adjusted to a laid-back position.



# TS spreading system

Perfection in every component, just like clockwork

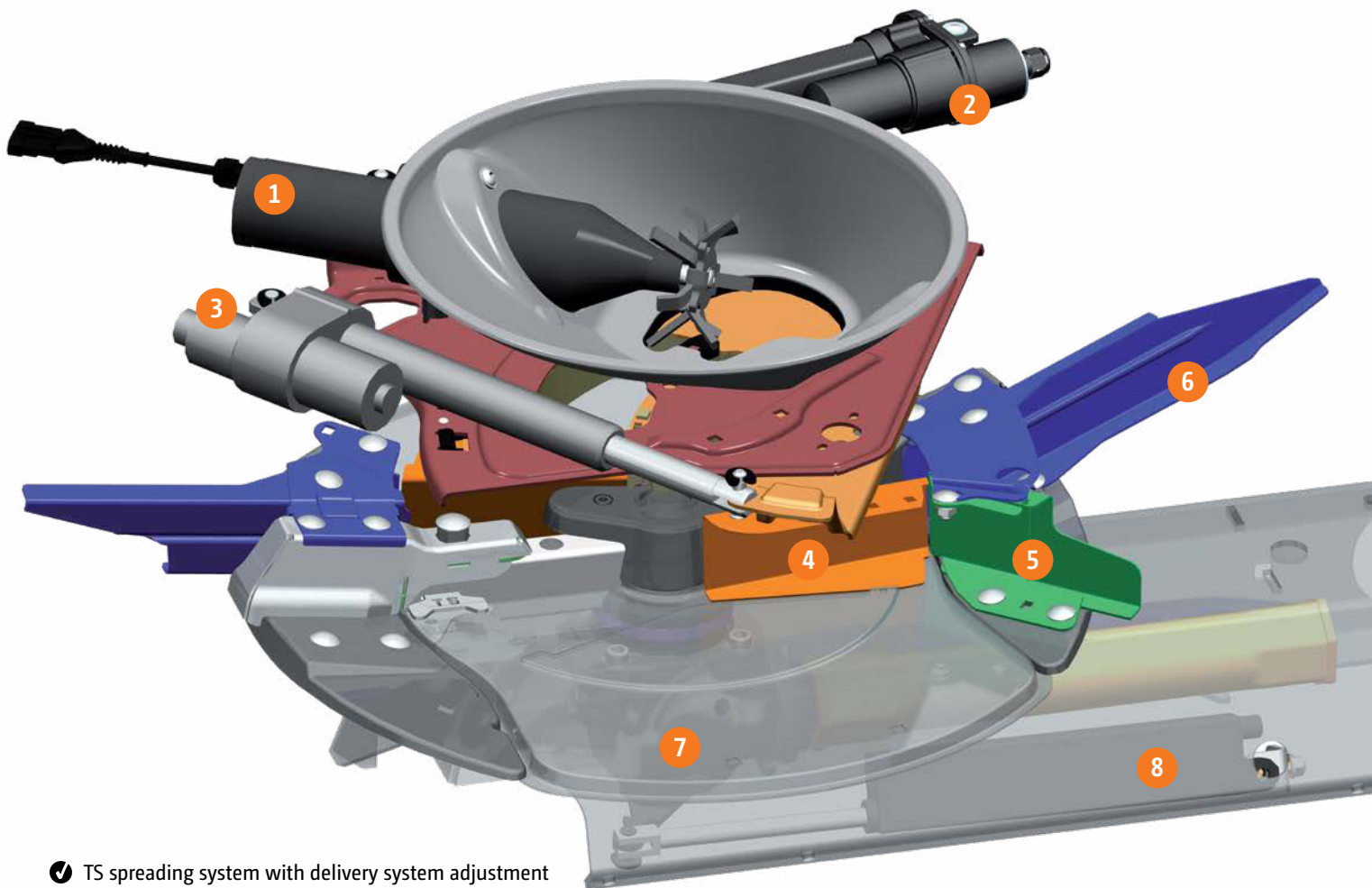

✔ TS spreading system with delivery system adjustment

## Composition of the TS spreading system

- 1) electric agitator drive
- 2) electric setting motor for rotating each delivery system
- 3) electric setting motor for the fertiliser metering
- 4) delivery vane
- 5) border spreading vane
- 6) normal spreading vane
- 7) AutoTS gearbox
- 8) electric setting motor for AutoTS including function check

## Characteristics of the TS spreading system

- ✔ Long throwing width, double overlap even at 36 m
- ✔ Integrated border spreading system
- ✔ High application rates (up to 10.8 kg/s or 650 kg/min)

- ❗ “A 12V motor drives the agitator which rotates at 60 RPM. It switches off when the shutter is closed and it reverses as soon as a foreign object blocks the agitator.”

(dlz agrar magazine – Long term test ZA-TS 3200 Profis Hydro · 02/2017)



## The agitator – soft-handling and gentle

The basic function of the agitator is to convey the fertiliser actively towards the outlet aperture so that a constant rate of fertiliser can be applied. Fertiliser lumps, which manage to pass the sieve, are, especially at low application rates, actively broken up via the star agitator which runs in the hopper bottom. If foreign objects reach the hopper tip and the agitator is subject to an overload, the relevant electric motor automatically reverses in combination with the relevant shutter slide and remedies the interruption autonomously. The perfect teamwork of agitator and shutter slides becomes obvious on headlands or when spreading in wedge-shaped fields. As soon as one metering aperture is completely closed, the agitator above stops automatically. In this way the valuable fertiliser is protected from being ground up.

### The benefits of electric agitation

- ✔ two slow-running, fertiliser saving agitators; turning at just 60 rpm
- ✔ that switch off automatically as soon as the shutter slide is closed, also just to the one side and independently of each other
- ✔ that reverse automatically when blocked by a foreign object
- ✔ active delivery of the fertiliser flow to the outlet aperture



- ❗ “The electric agitators operate independently left or right and only when that shutter is opened”

(profi – Practice test “Four fertiliser spreaders in comparison” · 01/2016)

# The AMAZONE delivery system

for first-class spreading results

## Concentric delivery system adjustment

The fertiliser is mainly deposited, via the delivery system, and thus in as gentle a manner as possible, at the centre-point of the spreading discs. The circumferential speeds are low at this point on the discs, and the fertiliser is handled very gently. For setting the spreading unit to different working widths and types of fertiliser, the delivery system is swivelled (concentrically) around the centre of the discs. The distance between the feed-on point of the fertiliser and the centre of the disc always remains the same.

The swivelling of the delivery system offers a wide bandwidth of possible working widths. The range of 15 m to 54 m working width is covered by just three sets of spreading vanes.

All TS spreading systems with electric delivery system adjustment are suitable for the ArgusTwin spread pattern monitoring system.

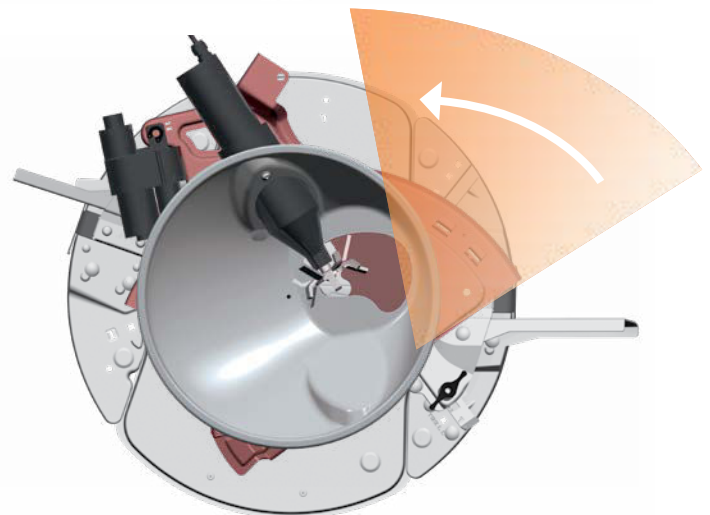
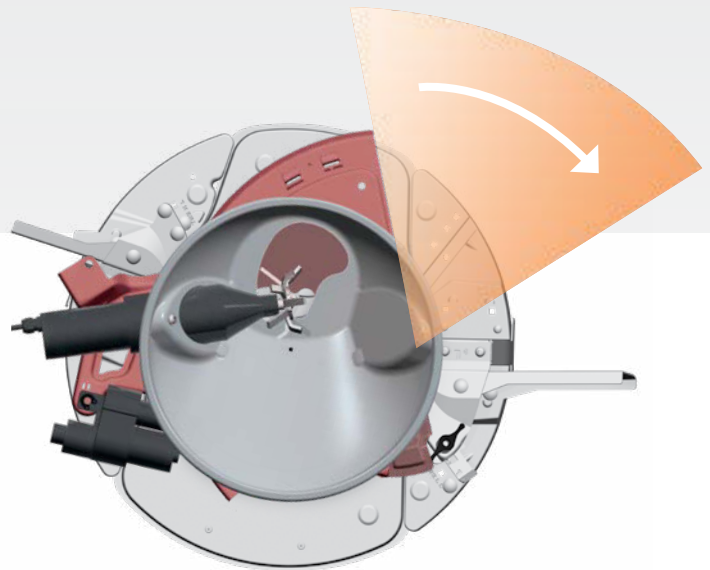

✔ The delivery system swivels around the centre of the disc



✔ Mechanical delivery system adjustment

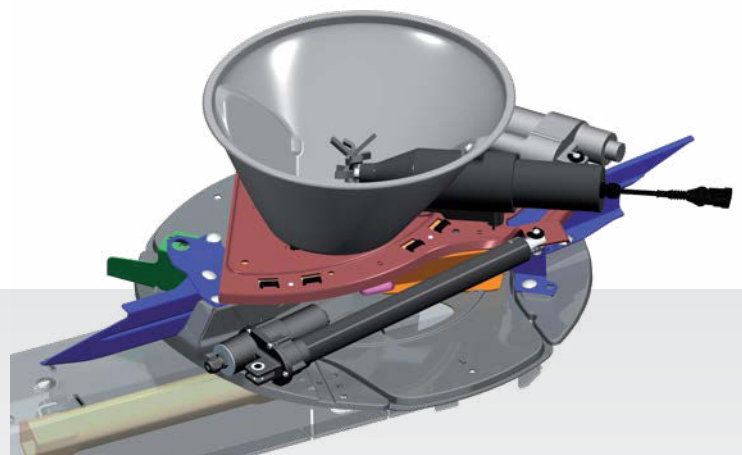

✔ Electric delivery system adjustment

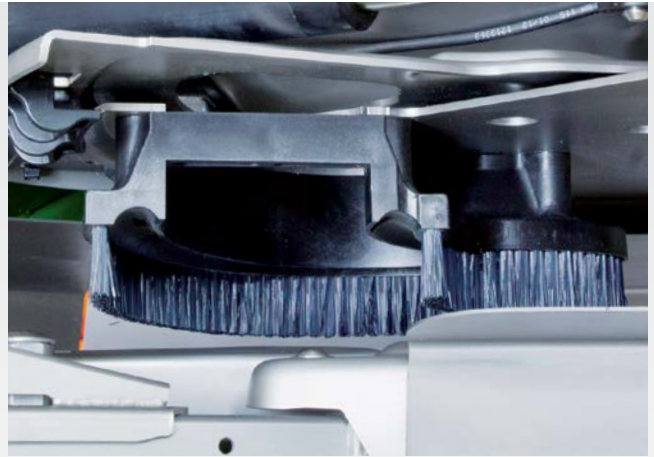

✔ Brush unit for a clean delivery onto the spreading discs

### Ultraquick and precise! Electric setting motors

A spreader which, due to the high application rates and operational speeds possible, explores new dimensions in terms of work rates and which, of course, needs to perform extremely precisely at the same time, requires setting motors that function extremely quickly and exactly. Especially in applications, such as the automatic on/off switching at the headland or in wedges, spreading using application maps or with the continuous on-board monitoring (ArgusTwin and WindControl), the setting motors ensure the highest level demands are met.

### Clean transfer – the brush unit

The bristles of the brushes which are fitted directly to the outlet apertures reach to the upper edge of the spreading vanes so that the fertiliser is safely delivered onto the disc.

### Quantity effect-free metering aperture

If it is intended to spread a constant application rate it is necessary to match the size of the metering aperture to the prevailing operational speed. Thanks to the shutter slide, this task is fulfilled very quickly and sensitively. Due to the

kidney-shaped design of the metering aperture, the spread pattern remains unchanged and precise, even at varying operational speeds so that the position of the delivery system does not require any adjustment.



Stage 1: Hopper aperture slightly open



Stage 2: Hopper aperture half open



Stage 3: Hopper aperture wide open

# TS spreading discs

For the utmost precision at all spreading widths up to 54 m

## Spreading system made from stainless steel – for a long service life

On the TS spreaders, the entire spreading system is made from stainless steel providing a long service life.

The vane change system enables the quick and easy change of just the spreading vane tips. The ideal solution, for example, for agricultural contractors.

Between normal spreading and border spreading, different spreading vanes are activated via the so-called AutoTS system without the necessity to change spreading disc settings.

### Hard-metal-coated spreading vanes

The spreading vanes are coated with a special long-lasting anti-wear protection. Consequently, the result is a three-fold increase in lifespan.

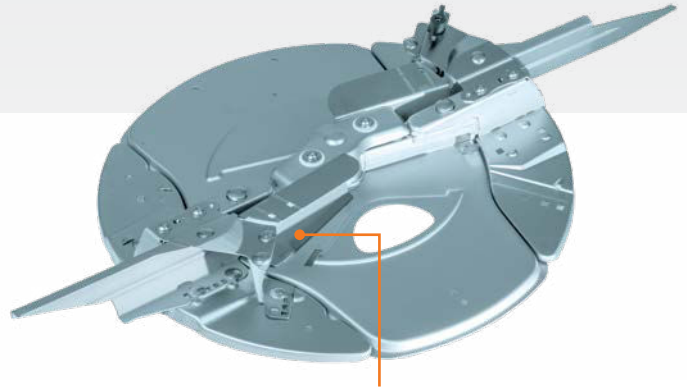

The integrated AutoTS border spreading system is activated electrically.

- “For different working widths it is then just a case of interchanging the spreading vane set – a very comfortable solution.”

(profi – Driving impression ZA-TS 4200 Profis Hydro fertiliser spreader– 06/2013)

### Optimum working width ranges of the spreading vane sets, depending on the fertiliser being spread:

- TS 10 = 15 m – max. 27 m
- TS 20 = 21 m – max. 33 m
- TS 30 = 24 m – max. 54 m

## Range of working widths for spreading vanes sets

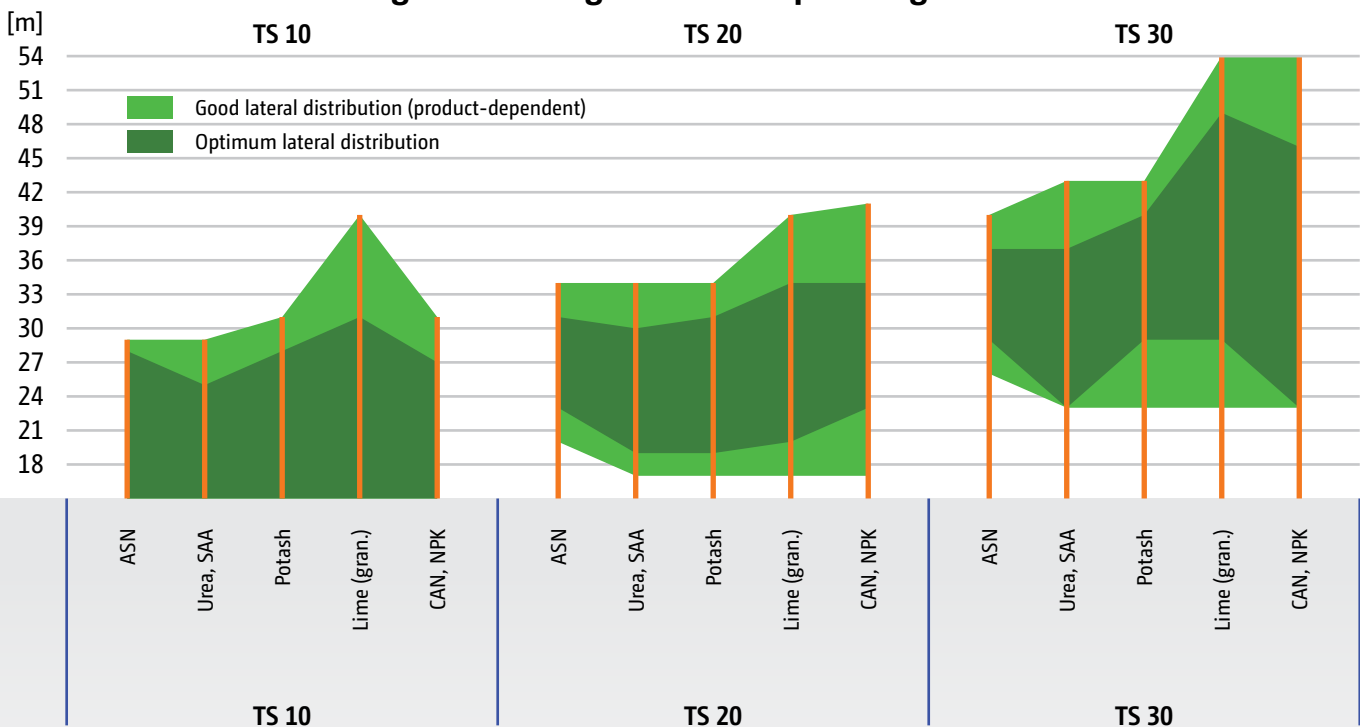

# Optimised spread pattern



## Normal spreading

Via the adjustment of the delivery system, the feed-on point of the spreading material on to the spreading disc is changed and thus the spreading width and the lateral distribution are controlled. In addition, the working width can be set even more individually by changing the disc speed.

## Non-sensitive spread pattern via the multi-sectional spread fan

The specific shape and angling of the spreading vanes result in a multi-spread fan from the TS spreading unit. This means that the long and short spreading vanes do not influence the spread pattern to either side and an optimum trajectory is maintained.

## Three-dimensional spread pattern

The spreading unit has been developed using three-dimensional spread patterns so that a perfect lateral distribution of up to 54 m working widths is achieved. The large overlap zones ensure a perfect spread pattern and are significantly more consistent with regard to any the external influences such as a side wind, change in topography, humidity and changing fertiliser qualities.

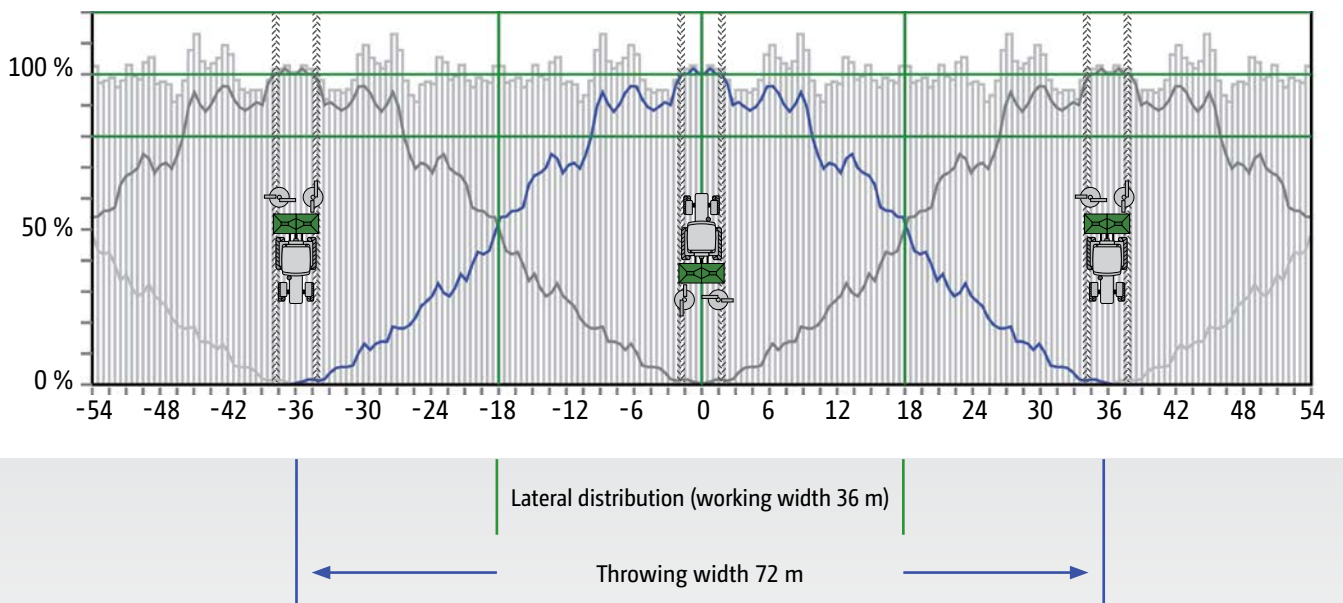
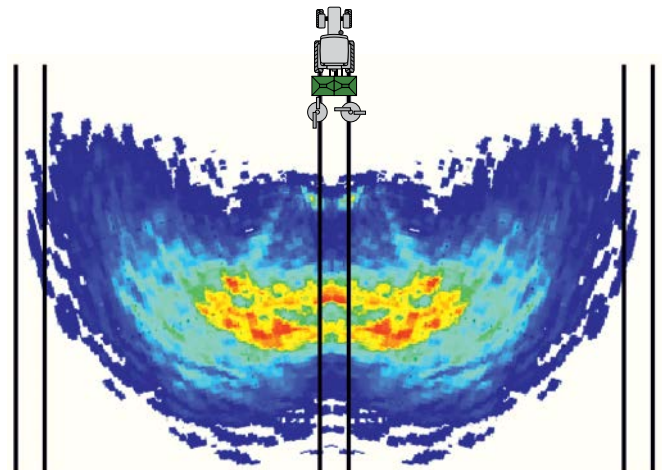

# Border spreading systems from AMAZONE

Complete control. At any time!



- ❗ Boundary spreading systems make particular sense when application rates are high. In these cases the more expensive systems will also pay off.  
(top agrar - "Precision goes boundary spreading" - 07/2022)

- ✔ AMAZONE offers setting recommendations for all border spreading techniques



## Effective and precise – spread only where the fertiliser will benefit plants

### Side spreading (yield-oriented adjustment)

The neighbouring field is an area that is used agriculturally. In this case it is tolerable for a small quantity of fertiliser to be thrown over the field border. The full target rate is applied right up to the field boundary.

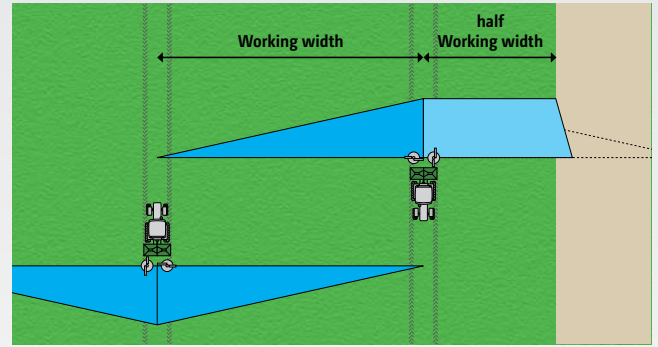

### Border spreading (environmentally-oriented adjustment)

If the field is adjacent to a road or cycle path, no fertiliser may be thrown beyond the field border. In this case, the throwing distance is adjusted in combination with the shutter slide.

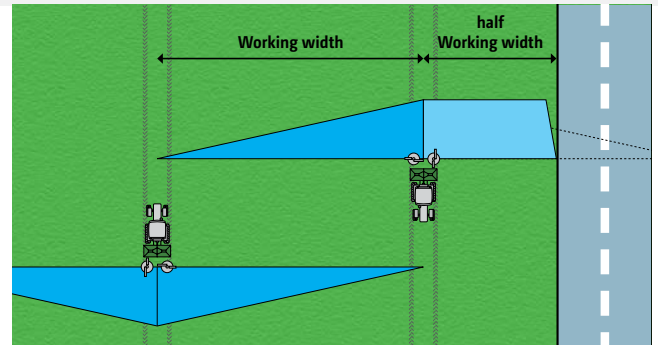

### Water-course spreading (environmentally-oriented adjustment)

If there is a body of water directly at the edge of the field, a defined distance away from the water must be maintained when fertilising according to the fertiliser regulations. For this purpose, the throwing distance is further reduced in combination with the shutter slide.

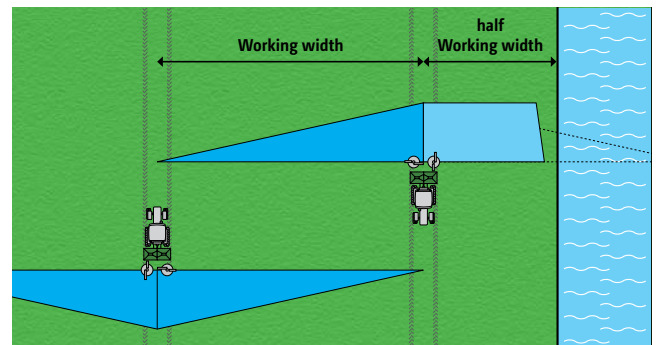

### BorderTS in combination with AutoTS

Using the BorderTS deflector means that the full target amount is applied at the field boundary, without spreading beyond it. In combination with AutoTS, the area between the first tramline and the field boundary is fertilised with the desired application rate. A sharp-edged cut-off right up to the field boundary is achieved.

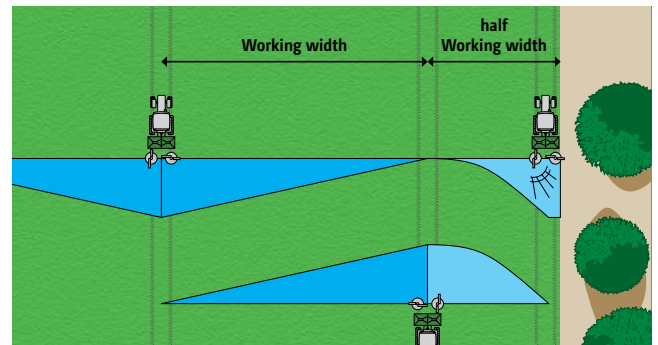

### Bed spreading with bed spreading deflector at both sides

For spreading specialist crops in beds to either side of the tractor AMAZONE offers the bed spreading deflector. It keeps the track virtually free from fertiliser. Actuation of the bed spreading deflector is carried out hydraulically from the tractor seat.

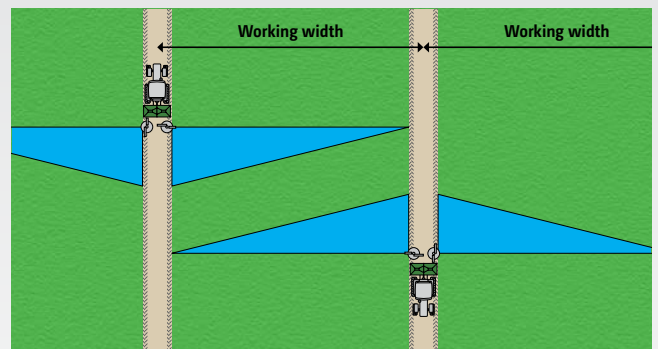

# AutoTS

## The disc-integrated border spreading system

### AutoTS – comfortable and precise Lateral distribution right up to the field border

The disc-integrated AutoTS border spreading system enables the activation of the different border spreading techniques – side, border or watercourse spreading – comfortably via the Terminal in the tractor cab, irrespective of which side.

### AutoTS - the ingenious principle

A setting motor twists the delivery vane forwards by approximately 10 ° so that, when border or watercourse spreading, the fertiliser is delivered via the shorter border spreading vanes. Due to the combination of disc speed and shorter vane, the fertiliser is thrown over a significant shorter distance without affecting it mechanically.



AutoTS – adjustment of the delivery vane for border spreading

- ① “The design specification for the development of the Amazone ZA-TS was clear: no longer should there be any compromise between normal spreading and side, border and watercourse spreading around the field boundaries.”

(profi – Spreading systems in practice “hydraulic or mechanical” · 06/2017)

#### AutoTS – setting for normal spreading



#### AutoTS – setting of delivery vane for border spreading



#### Border Spreading Calculator – calculate those additional profits

With AutoTS, an average increase in yield of about 17% can be achieved around the field boundary compared with other well-known systems. Calculate it for yourself now!

For tablet and desktop:  
[www.amazone.net/border-spreading-calculator](http://www.amazone.net/border-spreading-calculator)



- ✔ **Border spreading with ClickTS**  
 As an alternative to having the AutoTS system on both sides that can be controlled remotely from the tractor cab, there is now the option of AutoTS just on the one-side alongside the manually-adjusted ClickTS on the other. ClickTS is possible on both sides as well.



## Increased yield on the border thanks to AutoTS and ClickTS

The AutoTS and ClickTS border spreading systems generate a steep border spread pattern and thus the ability to provide the optimum growth conditions close to the field border. Compared to other border spreading systems, a significant increase in yield is possible.

Automatic rate reduction when border spreading is possible with the AutoTS spreading unit. Rate changes are possible in freely-selectable percentage steps. As the two spreading discs can be operated independently from one another, the change can be applied to one or both sides.

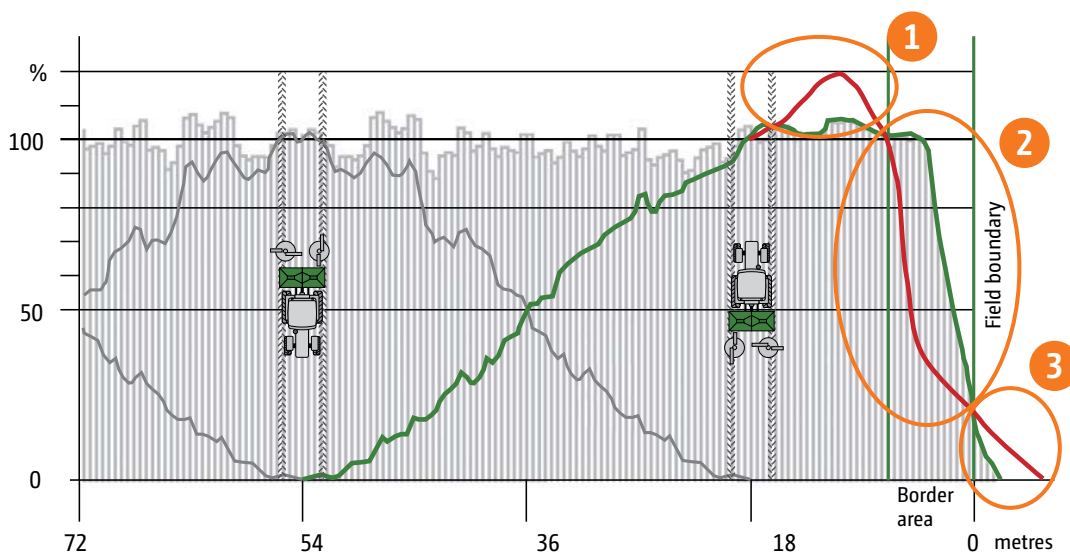

	AutoTS border spreading system	Conventional border spreading systems
<b>1</b>	A shorter spreading vane restricts the throwing distance of the fertiliser.	Mechanically diverting the fertiliser causes potential fertiliser damage, where the broken granules land next to the tramline.
<b>2</b>	The fertiliser is protected and optimally distributed up to the field boundary.	The broken granules are not spread out to the border area, resulting in under-fertilisation.
<b>3</b>	The lower throwing speed of the fertiliser means that fewer fertiliser granules fall beyond the field boundary.	Not all the fertiliser granules are mechanically deflected, meaning that some fertiliser is spread well beyond the field boundary.

# BorderTS border spreading system

Spread only where the plants will benefit from the fertiliser applied



## Maximum amount of fertiliser right up to the field boundary

AMAZONE has developed the BorderTS deflector for even more precise fertilisation up to the field boundary when spreading at those larger working widths. In contrast with conventional border spreading deflectors, the BorderTS deflector operates in collaboration with the AutoTS border spreading system integrated in the spreading discs. The spread patterns of both the BorderTS and the AutoTS are matched to each other.

All values can be stored in the spreader settings beforehand, so that the appropriate setting parameters are set automatically depending on the application situation.

- ❗ “With the BorderTS, Amazone presents extended version of AutoTS, which delivers the full rate right up to the boundary.”
- ❗ “...BorderTS can be used for base fertiliser applications, on grass land and in row crops. In addition, a pass is also possible for that initial application in cereal crops with tramlines, as in our case. The wheel tracks at the field edge disappear in time. The plants get the full fertiliser rate and start the new season in good shape.”

(profi - “Border work” - 04/2022)

- ✔ Using the BorderTS border spreading system enables increased yields of up to 27% on the outer five metres of the field boundary area when compared with conventional border spreading systems.

Animation BorderTS border spreading system:  
[www.amazone.net/yt-border-ts](http://www.amazone.net/yt-border-ts)





The BorderTS deflector is mounted centrally behind the spreader and is activated hydraulically.



When activated, the BorderTS deflector on the ZA-TS is swivelled into the spread fan from above. The special baffle plate construction and infinitely adjustable guide plate gently guide the granules to the ground.

### Baffle plate construction and with integrated software

At larger working widths, the fertiliser must be accelerated considerably more in order to achieve a good area of overlap with the spread fan from the first tramline. Due to the high energy of the granules, the evenness of distribution behind the tractor provided by conventional systems is often unsatisfactory. The BorderTS deflector features a special baffle plate construction and a guide plate, the angle of which can be adjusted. The baffles first remove the energy from the granules, which are then gently guided to the ground by the guide plate. The guide plate is infinitely adjustable for optimal application up to the field boundary. In addition, a sensor detects the working position. When the deflector is in use, the spread rate and the delivery point of the fertiliser onto the spreading disc are automatically adjusted to ensure the best possible lateral distribution in combination with the disc-integrated AutoTS border spreading system.

It goes without saying that the application rate can be manually overridden at any time in response to special situations.

❗ “Checking with the mats at the field boundary showed the effectiveness of the deflector in our application. At the same time, the fertiliser rate for the field was applied right up to the boundary after driving in the tramline and round the outside – excellent.”

(profi - “Border work” - 04/2022)

### Illustration of the combined use of BorderTS and AutoTS

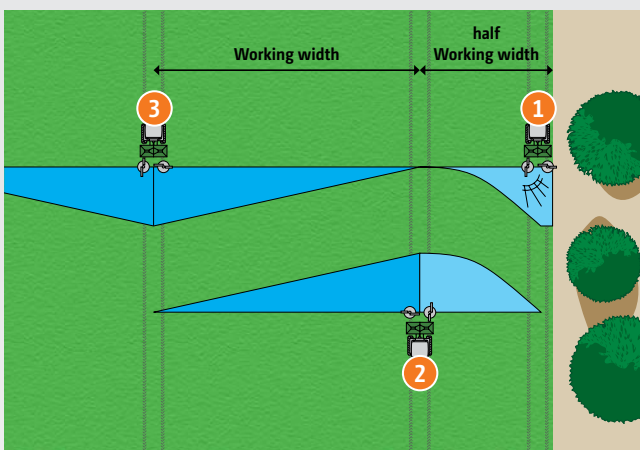

1. Fertiliser is spread from the edge of the field into the crop by the BorderTS deflector, with automatic reduction of the target rate to 50%. The shutter nearest the field boundary is left closed.
2. AutoTS spreads at 50% from the first tramline to the boundary side in order to achieve the target rate across the total field boundary area. Normal spreading to the field side with 100% of the target rate.
3. In the subsequent tramlines, normal spreading is resumed with 100% of the target rate to both sides.

# Proven precision!

Innovation Farm field trial

INNO  
VATION  
FARM 

FARMING FOR FUTURE



- ✔ Large-scale field trials by Austrian Innovation Farm compared four border spreading systems under practical conditions.

Additional revenue per hectare of cropped area and per year with the use of the different border spreading systems at a width of 36 m (top agrar 07/2022, Source: Innovation Farm)

average field size	2 ha	4 ha	12 ha
Limiter	€ 52.28	€ 36.96	€ 21.35
Hydro	€ 56.04	€ 39.61	€ 22.89
AutoTS	€ 117.02	€ 82.71	€ 47.79
BorderTS	€ 121.22	€ 85.68	€ 49.50

## Field trials prove the best border spreading results

The aim of the field trial was to demonstrate the fact that border spreading systems provide not only ecological benefits, but also that they have a great influence on the potential yield in the field boundary area.

Precise technology is required to spread the full rate of fertiliser right up to the field boundary, even at the larger working widths, as well as avoiding any fertiliser losses outside the field boundary.

AutoTS and BorderTS fulfil these requirements. This means that higher yields can be expected, even at the field boundary.

## Core messages of the trial

- ❗ “A wider working width or smaller field size increases the size of the return on a boundary spreading system.”
- ❗ “The AutoTS and BorderTS spread patterns show a relatively even spread rate all the way up to the boundary where the rate then drops steeply.”
- ❗ “Below average dosage was clearly reduced by using AutoTS and BorderTS, which translates into higher yields..”
- ❗ “This means that AutoTS and BorderTS should be utilised at the larger working widths.”

(top agrar - “Precision goes boundary spreading” - 07/2022)

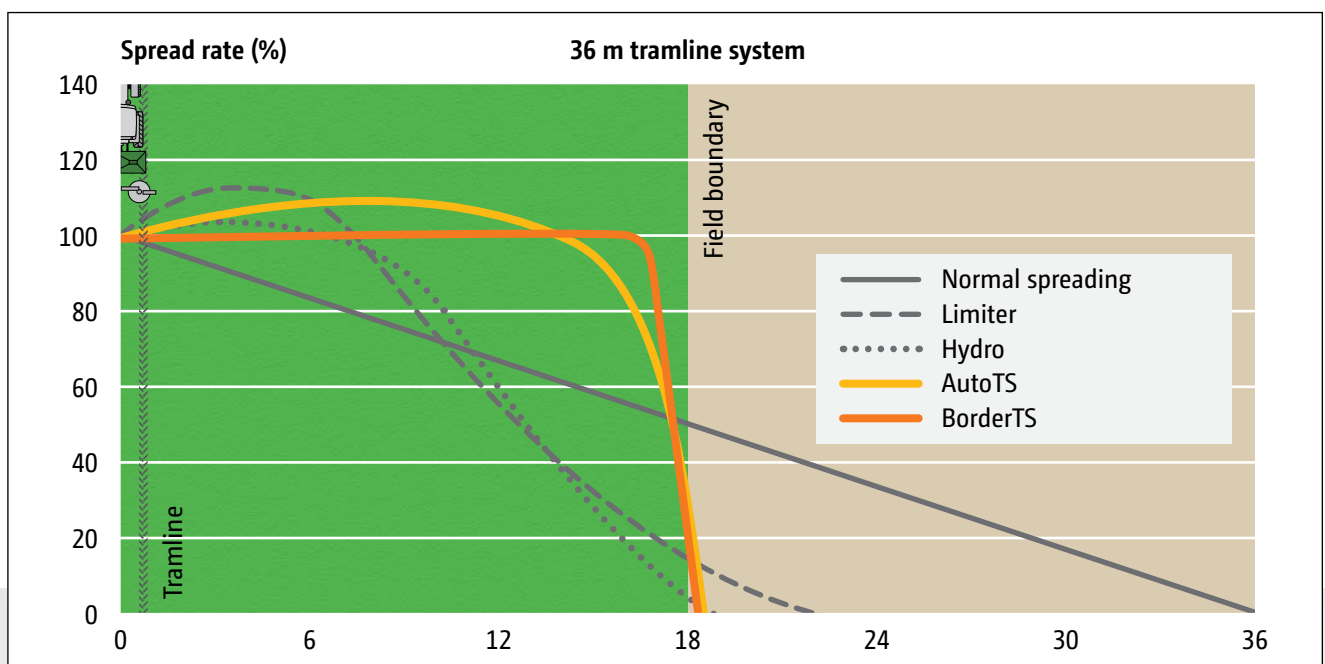

- ❗ “... This was different on AutoTS and BorderTS which continued to apply a very even spread.”

(top agrar - “Precision goes boundary spreading” - 07/2022)

# HeadlandControl

Optimum lateral distribution on the headland

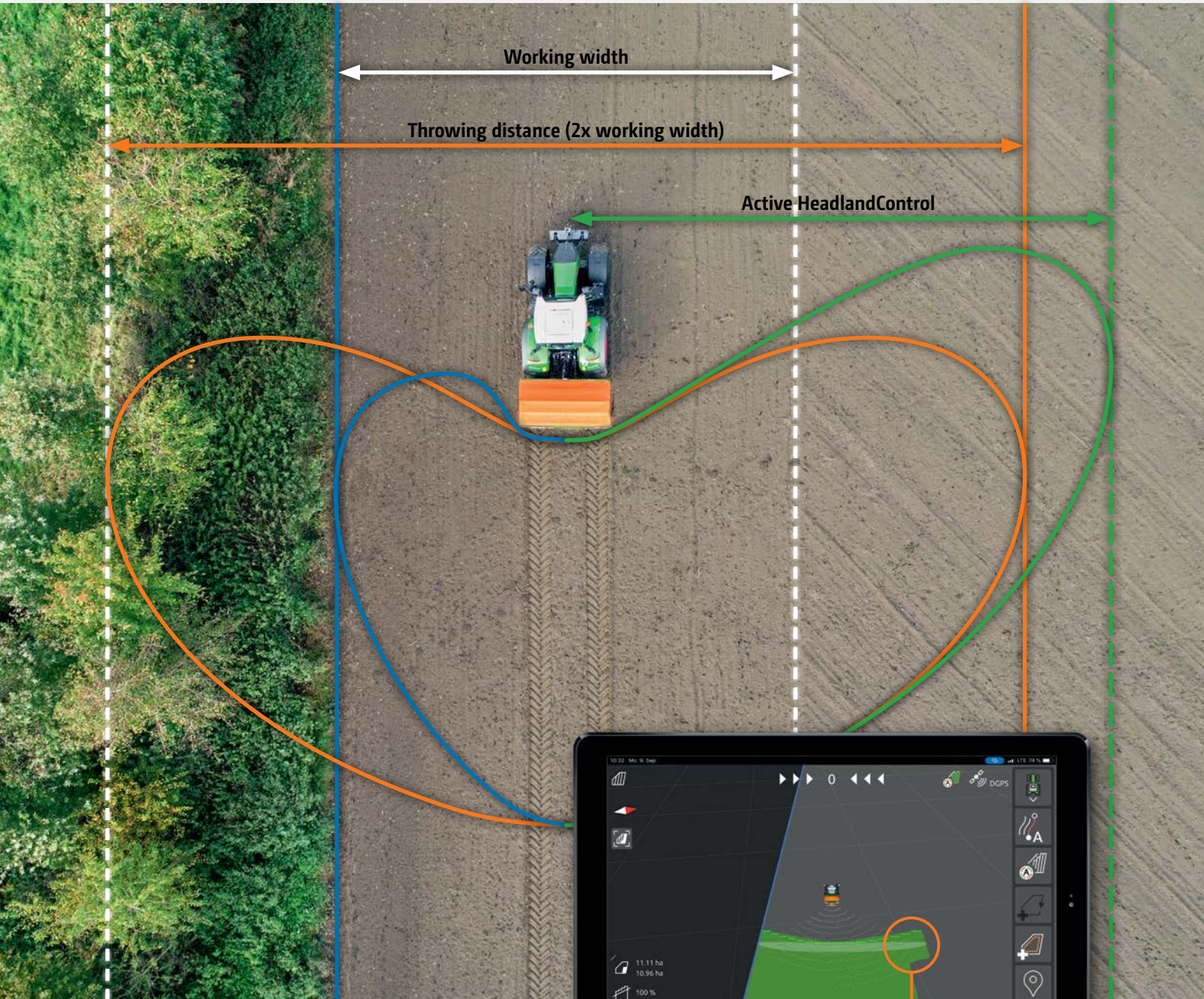

- HeadlandControl
- Normal spreading
- Border spreading

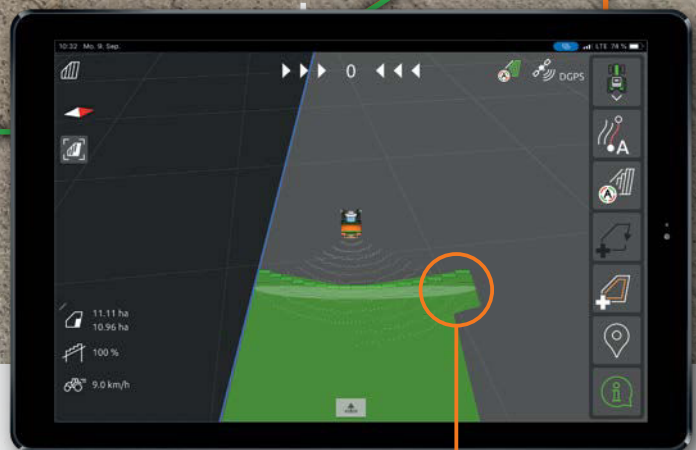

HeadlandControl provides an increase in the working width towards the inside of the field on the headland.



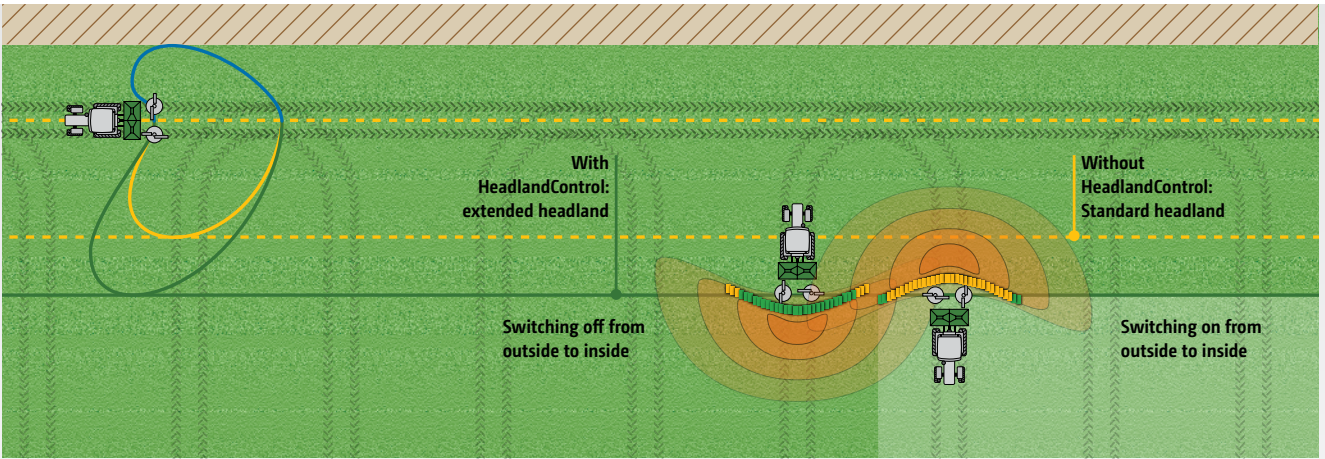

Perfected headland coverage thanks to HeadlandControl and the new part-width section control

### The problem: over- and under-fertilisation on the headland

Different fertilisers have different switch-on and switch-off points. In practice, the switch-off points are usually only achieved when the tractor is turning on the headland. The arc of spread behind the tractor and round to the side creates areas that are either over- or under-fertilised.

### Switch-off time on the headland: Without HeadlandControl

1. Spreader switches off too late and is already turning
2. Tractor would have to drive beyond the headland tramline

**Result:** over- and under-fertilised zones are created

### The solution: HeadlandControl

When HeadlandControl is activated, the throwing width and spread rate are increased on the field side, so that the switch-off point is moved towards the inside of the field. Furthermore, the new part-width section control, which is now adapted to the shape of the spread fan, causes the part-width sections to be switched off from the outside to the inside when entering the headland. Over- and under-fertilised zones on the headland are subsequently avoided.

### With HeadlandControl

1. HeadlandControl means that the spreader continues to apply fertiliser to the crop when it is on the headland
2. The tractor can follow the wheel tracks of the crop protection sprayer

**Result:** uniform crops across the headland

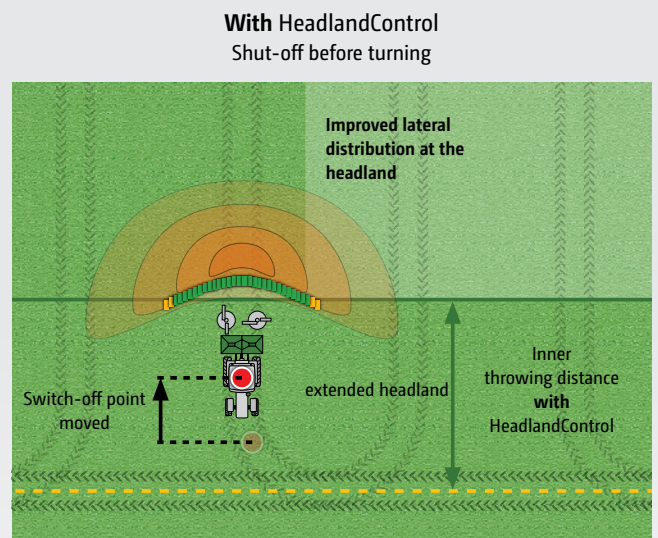
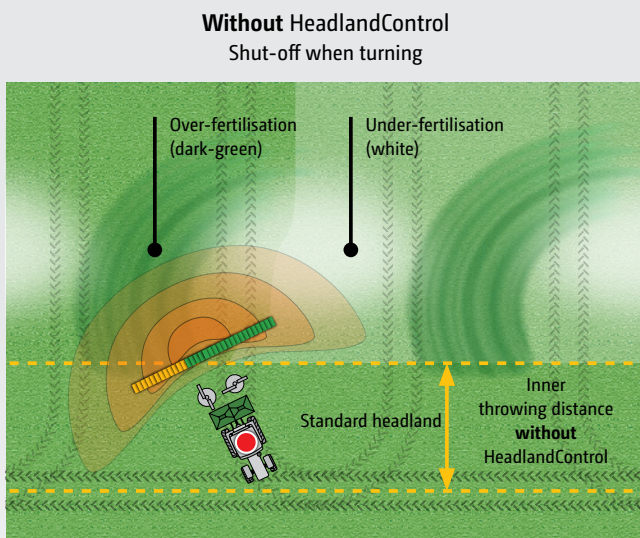

# WindControl – don't give wind a chance

AMAZONE WindControl is now available independently of ArgusTwin.



AMAZONE WindControl ensures an optimum lateral distribution even in crosswinds

More Information:  
[www.amazone.net/en-windcontrol](http://www.amazone.net/en-windcontrol)



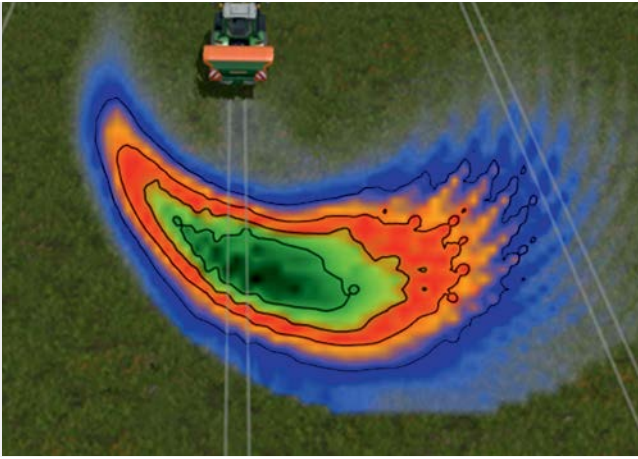

**Without WindControl:** Crosswinds affect the spread pattern and change the lateral distribution

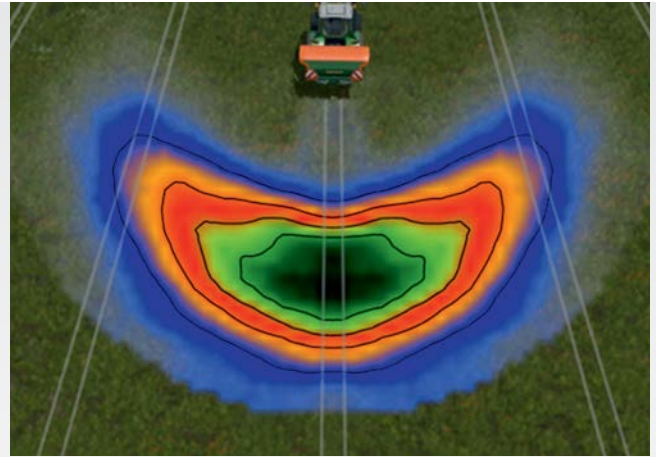

**With WindControl:** WindControl counteracts the effect of a crosswind ensuring an optimum spread pattern at all times

## Optimum lateral distribution

The wind is always blowing somewhere in the world and this represents a major challenge in maintaining an even fertiliser spread pattern. The influence of wind on the spread pattern can be constantly monitored and automatically compensated for with the AMAZONE WindControl system (according to Prof. Dr. Karl Wild of the University of Applied Sciences, Dresden). Practical trials have shown that the system reacts actively to wind influences for approximately 80% of the spreading time and provides optimisation of the spread pattern.

Mounted on the machine, a high frequency measuring wind sensor, registers both the wind speed and also the wind direction. According to this data, the job computer then calculates new settings for the delivery system and the spreading disc speed. In a cross wind, the disc speed is

increased on the side into the wind and the delivery system is rotated outwards. At the same time, the speed of the downwind side is reduced and the delivery system rotated inwards.

With the aid of WindControl, larger time windows are created for spreading under the influence of wind. Apart from all the important fertiliser spreader parameters, the user additionally always has, in view, the real-time direction of the wind, the force of wind and if the wind is gusting. In addition, in heavy winds, when the system is no longer able to compensate for, or when the wind gusts are too frequent, WindControl sends an automatic alarm to the driver.

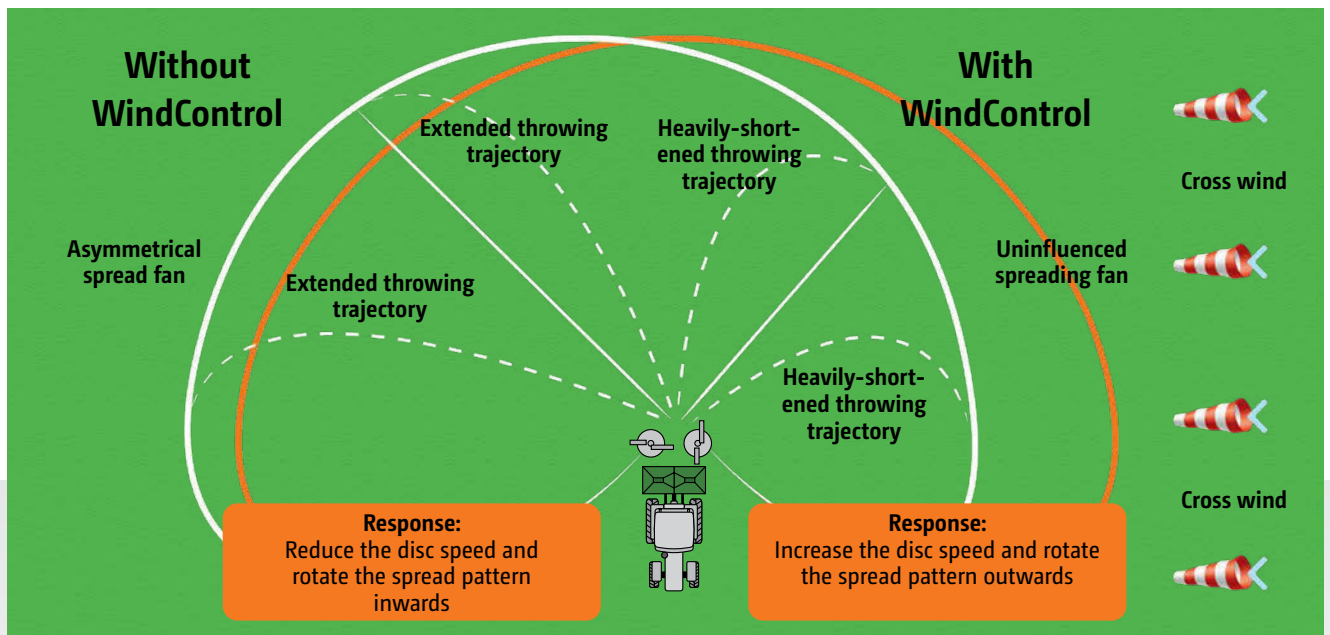

# ArgusTwin

The spreader's eyes – it sees what you don't see!



**Argus**

❗ “ArgusTwin optimised the lateral distribution within seconds.”  
 (“profi” – Test report Amazone ArgusTwin · 01/2016)

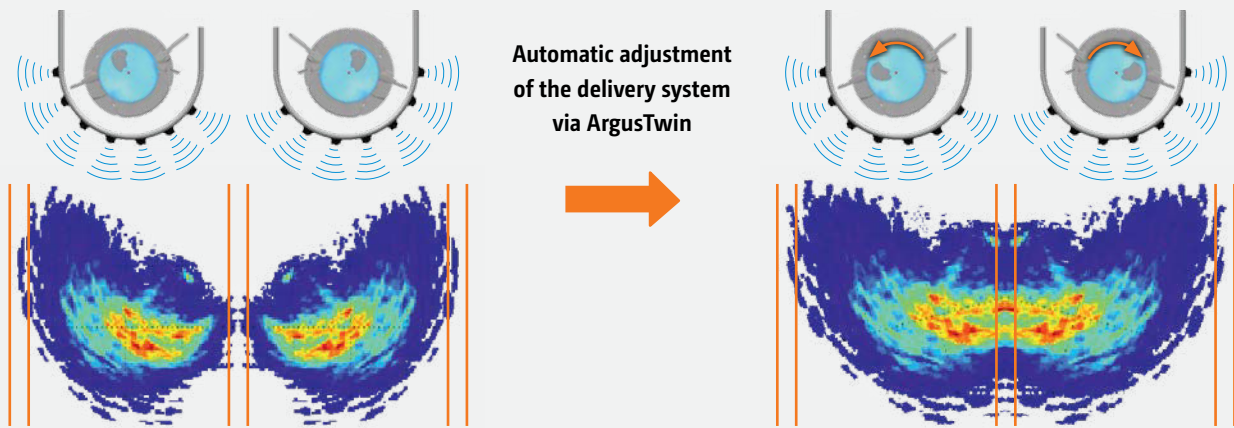

The problems in practice – poor lateral distribution, for instance, due to a change in fertiliser properties

Perfect lateral distribution enables uniform crops, even with varying fertiliser quality and properties

## Automatic adjustment to the optimum lateral distribution

Via the constantly working on-line monitoring and readjustment of the delivery system, the ArgusTwin system ensures an optimum lateral distribution of the fertiliser. This leads to a more effective fertiliser use and forms the basis for optimum crop management.

The Argus system, which checks the spread fan and automatically regulates the lateral distribution, is based on radar technology that is independent of dust and pollution and thus provides reliable results in practice. ArgusTwin constantly monitors, via radar sensors mounted on both the sides of the spreader, the left and right hand spread fans simultaneously and re-adjusts the electric delivery system independently of each other if necessary.

## Automatic delivery system adjustment

Via the ISOBUS terminal, the application rate, and any further relevant data relating to the fertiliser to be spread, are entered from the setting chart. For the Argus system, the spreading chart has been updated to include the throwing angle that gives the optimum lateral distribution. Utilising this value, ArgusTwin constantly checks whether the predetermined direction of throw for that fertiliser is in fact being maintained by the spreading discs. When the actual

throwing width deviates from the “desired” throwing width due to inconsistencies within the fertiliser, worn spreading vanes, working across slopes or during starting and stopping procedures, the spreader readjusts, on its own, the setting for the delivery system – and that of each side individually. The only pre-condition for its use is the electric delivery system adjustment.

## The benefits

- ✔ Constant on-line monitoring of both spread fans
- ✔ Maintains an optimum lateral distribution of the fertiliser even with:
  - variable fertiliser quality
  - environmental influences, such as moisture and dew
- ✔ Automatic slope compensation of the spread pattern by readjustment of the delivery system position
- ✔ Basis for optimum crop management
  - More effective use of the fertiliser
- ✔ The system is also active when border spreading, or if a part-width section is switched on or off
- ✔ Positioned protected directly above the spreading discs

# Optional equipment

Perfect down to the last detail



## SafetySet – integrated as standard

The SafetySet, which is fitted as standard equipment ensures improved safety. The outer guard tube fulfils the accident prevention regulations. Large marker boards to the rear and the LED road lighting kit ensure more recognisability in road traffic.

## Holder for the GPS receiver on the fertiliser spreader

The holder, including a 12 m GPS connecting cable, serves to mount a GPS receiver on the fertiliser spreader instead of on the tractor. The GPS receiver can remain on the spreader if the tractor is changed frequently, such as with machine cooperatives. In use, the GPS receiver is always located clearly above the fertiliser spreader.

## Roll-over cover

The roll-over hopper cover, either manually operated or hydraulically-actuated from the tractor, is available for all S extensions and L extensions. It safely covers the whole of the hopper access area and ensures, when compactly rolled up, the maximum filling opening. The roll-over hopper cover can also be combined with the bolt-on S 600 and L 800 extensions.

## Swivel hopper cover

As a cost-effective alternative to the roll-over hopper cover, the swivel hopper cover, with large sight windows can be chosen but only for the S extensions.



Swivel hopper cover, in its maintenance position for a simpler internal cleaning

❗ “The roll-over cover is good: it closes off neatly, keeps the water out during a shower and does not interfere with the filling operation when open/rolled up.”

(dlz agrar magazine – Long term test ZA-TS “Wide throwing master” · 01/2016)



❗ “The robust (and steered at the front) parking rollers with brakes are swivelled in or out with a bold kick. There is no better way.”  
 (profi – Practice test “Four fertiliser spreaders in comparison” · 01/2016)

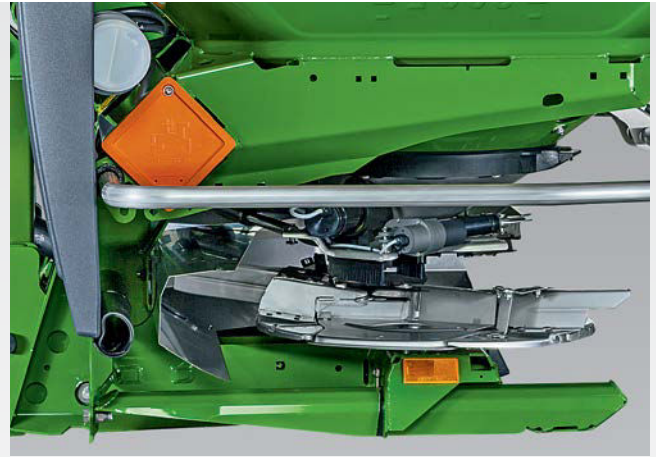

✔ Parking device with integrated stands

## Swivel rolling and parking device

The swivel rolling and parking device facilitates the easy mounting on and off the tractor and manoeuvring in the yard. The castor wheels are quickly folded in and out and optimally protected from dirt. They are permanently mounted on the spreader – so no need to search for them between one location and another.

## Calibration device

For the comfortable spread rate check without removal of the spreading disc, the lateral calibration kit, left or right hand side, is available.



Calibration device

## Parking device options

As an alternative to the swivel rolling and parking device, there is also a cheaper parking stand with integrated skid available.

## Ladders that ensure a safe access

For optimum access to the hopper from outside, even on the narrow extensions, a ladder is available which can be fitted to the left and/or right hand side. For the wide L extensions though, ladders are provided to both sides as standard.



❗ “Amazone sets the standard, even with the ladder: The rungs (stainless steel) are well integrated on both sides and do not protrude.”

(profi – Practice test “Four fertiliser spreaders in comparison” · 01/2016)

# Let there be light

## Multiple benefit of the working lights



The lighting for spreading unit is integrated securely in the lighting carrier.

### Spread fan, spreading unit and hopper internal lighting

An optional work light kit is available as a supplement to the standard LED lighting for the ZA-TS mounted spreader.

LED work lights are mounted in the hopper above the spreading discs and at the sides of the spreader. This ensures that the user has an overview of the fill level in the hopper at night, and has adequate lighting for changing the spreading discs and for setting the telescopic blades on the spreading vanes.

The work lights are fully integrated in the software of the fertiliser spreader and can therefore be operated remotely from the tractor cab via the ISOBUS terminal.

The two side-mounted LED work lights provide perfect illumination of the spread fan to the left and right in the dark.

### Filling aid

Practical users will particularly love the filling aid provided by the work lights and the Profis weighing system. Flashing followed by the constant lighting up of the work lights signals that the fill level has been reached. A second person, or frequent dismounting for checking, are no longer necessary.



Lighting for the inside of the hopper



The preset capacity is achieved when the work lights comes on continuously.



# Front-Rear duo

A new level of precision



A road lighting kit is available for safe road use when in transport with the front-mounted spreader.

## Two into one goes

For customers who intend to accurately spread two different mineral fertilisers in just one pass, AMAZONE offers the unique possibility of a front-mounted spreader. Other than when utilising blended fertilisers in one fertiliser spreader, this option allows the optimal setting of each spreader according to the properties of the relevant fertiliser. In this way, the perfect lateral distribution for both fertilisers is achieved. Also spreading with two different application maps is possible.

## The benefits of front-mounting

- ✔ Possibility to accurately spread two different types of fertiliser in just one pass
- ✔ More capacity from the additional hopper capacity yet with the benefits of a mounted machine – manoeuvrable and speedy
- ❗ “The spreader duo shows its strengths in its precision.”
- ❗ “The combination is manoeuvrable, efficient and improves the weight distribution on the front and rear axle.”  
(agrarheute magazine– test report with the front mounted spreader · 09/2018)

## Comfortable and reliable

To enable operation of a “reversed” fertiliser spreader on the front of the tractor, an intelligent software package is utilised which reliably mirrors the spreading function and required working without any rethinking. In this way, even

normal, side, border and watercourse spreading can be actuated on the correct side without any problems. Even the optimum switching points for the automatic on/off switching on the headland is matched.



- ✔ Precise spreading of two different fertiliser types

# ZA-TS model overview

Always the right choice



With the tractor ISOBUS base equipment, all the benefits of the ZA-TS can be utilised even on older tractors

# One spreader – so many possibilities

Decide for yourself!

	<i>ZA-TS Tronic</i>	<i>ZA-TS Profis Tronic</i>	<i>ZA-TS Hydro</i>	<i>ZA-TS Profis Hydro</i>
<b>Basic machine</b>				
Electric shutter actuation	●	●	●	●
Electric agitator	●	●	●	●
Electric delivery system	○	○	○	○
Forward speed-dependent spread rate regulation	●	●	●	●
Low level sensors	○	○	○	○
<b>Border spreading device</b>				
Border spreading AutoTS	○	○	○	○
Border spreading with BorderTS <small>(manual/electric delivery system)</small>	– / ○	– / ○	– / ○	– / ○
Bed spreading via bed spreading deflector	○	○	○	○
<b>On-line spread rate calibration</b>				
Profis weighing system	–	●	–	●
ProfisPro weighing system + torque measuring	–	○	–	○
Tilt sensors	–	○	–	○
<b>Optimisation of the lateral distribution</b>				
ArgusTwin <small>(manual/electric delivery system)</small>	– / ○	– / ○	– / ○	– / ○
WindControl <small>(manual/electric delivery system)</small>	–	–	– / ○	– / ○
HeadlandControl <small>(manual/electric delivery system)</small>	– / ●	– / ●	– / ●	– / ●
<b>Part-width section control</b>				
Incorporating the delivery system adjustment <small>(manual/electric delivery system)</small>	– / ●	– / ●	– / ●	– / ●
Incorporation of spreading disc speed	–	–	●	●
Max. number of part-width sections <small>(manual/electric delivery system)</small>	8 / 16	8 / 16	128 / 128	128 / 128
<b>Mode of operation</b>				
Terminal	ISOBUS	ISOBUS	ISOBUS	ISOBUS
Automatic documentation	●	●	●	●

● Standard   ○ Option   – not available

# ISOBUS as the basis for intelligent communication

## One language, many benefits!

Each ISOBUS-enabled machine from AMAZONE comes with the latest technology and almost unlimited possibilities. It makes no difference whether you use an operator terminal from AMAZONE or an ISOBUS terminal fitted directly in the tractor. ISOBUS is an internationally recognised standard for communication between the operator terminal, tractors and connected implements on the one hand and Farm Management Information Systems on the other.

## Operation via a wide-range of ISOBUS terminals

Which means that ISOBUS enables you to take control of all your ISOBUS compatible equipment. You only have to connect the machine to the respective ISOBUS terminal and the usual operator interface appears on the monitor in your tractor cab.

### Benefits of ISOBUS at a glance:

- ✔ This worldwide standard provides a uniform interface and data exchange format that ensures compatibility even with third party manufacturers
- ✔ Plug and Play between machine, tractor and additional ISOBUS implements



AMAZONE ISOBUS terminals  
AmaPad 2 and AmaTron 4



# Perfectly developed machine operation from AMAZONE

**AMAZONE machinery and operator terminals offer a range of functions which are very easy and safe to operate:**

- ✔ Highest compatibility and function flexibility of your ISOBUS equipment
- ✔ No additional modules on the machine side. All ISOBUS machines from AMAZONE come ready-equipped with the necessary ISOBUS functions as standard
- ✔ Practice-oriented machine software and logical menu structure
- ✔ MiniView display with all AMAZONE terminals and additional ISOBUS terminals. See e.g. the machine data in the map view.
- ✔ Possibility of operating the machine via the tractor terminal or a twin terminal solution
- ✔ Flexible assignment of the map and machine view between the tractor terminal and the operator terminal
- ✔ Unique operation concept. Freely-configurable displays and individual user interfaces for each driver
- ✔ Useful additional functions such as automatic boom lowering on AMAZONE crop protection sprayers
- ✔ Integrated TaskController data logger function



Clearly structured AMAZONE machine operation

**Advantages of the AMAZONE machine software:**

- ✔ User-oriented and intuitive
- ✔ Tailored to the machine
- ✔ Functional range above and beyond the ISOBUS standard

Clear display of the work menu in the AMAZONE machine operation



# Automatic GPS-Switch part-area shut-off with Section Control

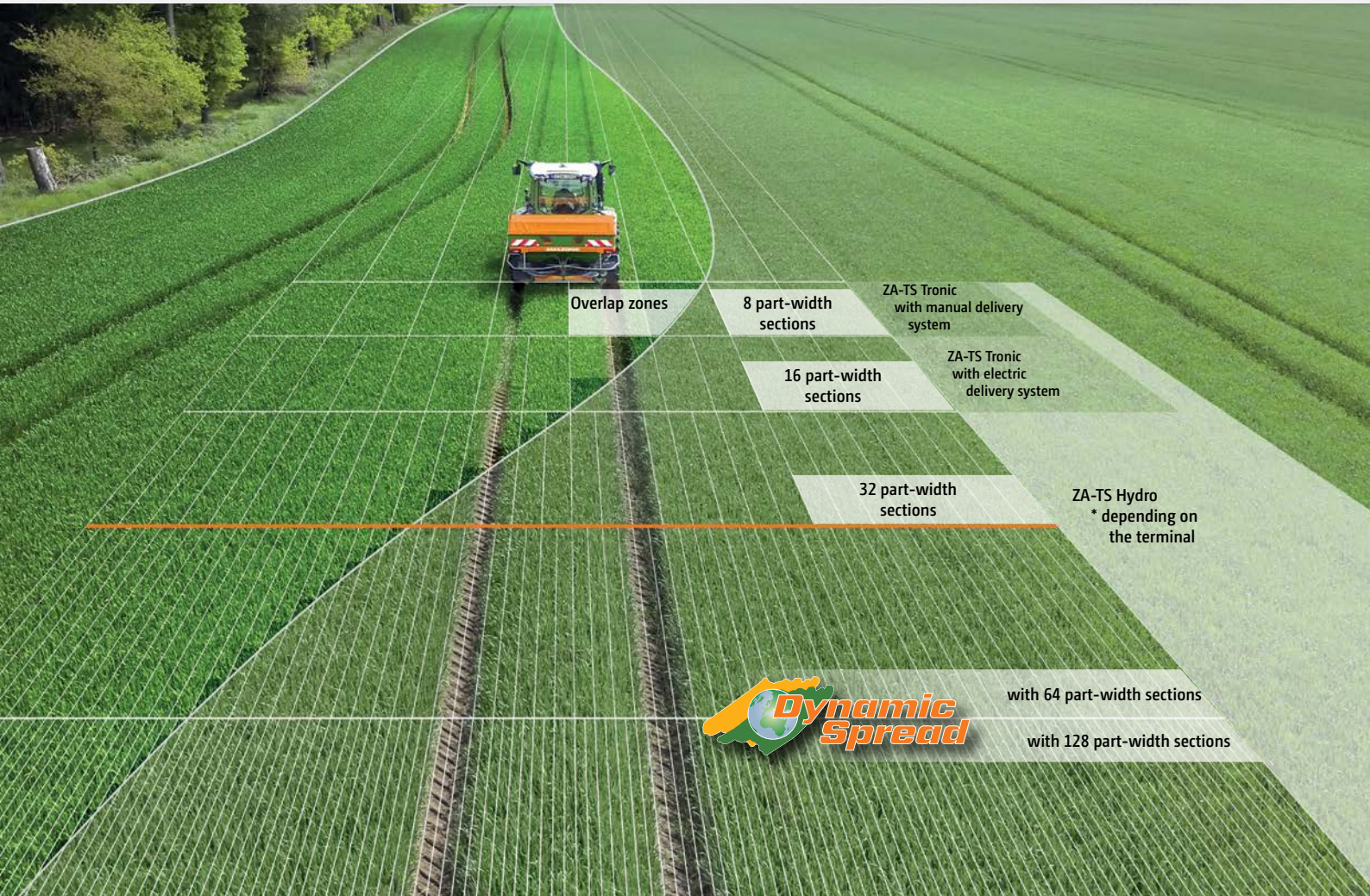

✔ With DynamicSpread, individual outlying part-width sections can also be controlled.

## More precision, more efficiency!

In view of the very large working widths used now, the matching of the spread patterns is very important. Thanks to the electric delivery system adjustment on the TS spreading system, it is able to react precisely and sensitively in these cases. So even outer part-width sections can be easily controlled. In addition, due to the individual speed adjustment of the left and right hand side discs, the spreading width can be reduced from the far outside

to the centre, so that, even at large working widths, long and shallow-shaped wedges and short work are optimally spread. This means part-width section control. At the simplest level of specification, 8 part-width sections can be easily actuated manually (via the operator terminal). When utilising a relevant Section Control licence on the terminal, a part-width section control of up to a maximum of 128 part width sections can be utilised.

Part-width section control for ISOBUS fertiliser spreaders	ZA-TS Tronic Manual delivery system adjustment	ZA-TS Tronic Electric delivery system adjustment	ZA-TS Hydro Manual delivery system adjustment	ZA-TS Hydro Electric delivery system adjustment
Spread rate regulation	X	X	X	X
Setting the delivery system		X		X
Matching the spreading disc speed			X	X
Number of part-width sections • Manual mode via key pressure • Automatic mode via SectionControl/GPS-Switch	8 In manual and automatic mode	8 In manual mode  16 In automatic mode	8 In manual mode  up to 128 In automatic mode	8 In manual mode  up to 128 In automatic mode
Possible working widths	15–54 m	15–54 m	15–54 m	15–54 m

If the operating terminal facilitates Section Control, such as GPS-Switch part-width section control from AMAZONE, the part-width sections are activated completely automatically and in relation to the GPS position. Once a field has been created, the driver can concentrate fully on operating the vehicle in automatic mode, since the part-width sections are switched automatically in wedge shaped fields and on headlands.

**Benefits of automatic part-width section control:**

- ✔ Stress relief on the driver
  - ✔ Increase in precision especially at night or at higher speeds
  - ✔ Fewer overlaps and gaps
  - ✔ Saving on input costs
  - ✔ Less crop damage and less environmental pollution
- ❗ “With Section Control, the ISOBUS terminal takes a lot of work away from the driver.”  
 (“dlz agrar magazine” – test report ZA-TS fertiliser spreader · 02/2017)

## GPS-Switch

With GPS-Switch, AMAZONE offers GPS-based, fully automatic, part-width section control for all AMAZONE operator terminals and ISOBUS-compatible fertiliser spreaders, crop protection sprayers or seed drills.

**GPS-Switch basic**

- ✔ Automatic part-width section control for up to 16 part-width sections
- ✔ Creation of a virtual headland
- ✔ Automated boom lowering with an AMAZONE crop protection sprayer
- ✔ Standard with AmaPad 2
- ✔ Optional with AmaTron 4

**GPS-Switch pro** (as an add-on to GPS-Switch basic)

- ✔ Automatic part-width section control with up to 128 part-width sections, particularly for crop protection sprayers with individual nozzle control
- ✔ Marking of obstacles (e.g. water holes, pylons)
- ✔ Auto-zoom when approaching the headland
- ✔ Standard with AmaPad 2
- ✔ Optional with AmaTron 4

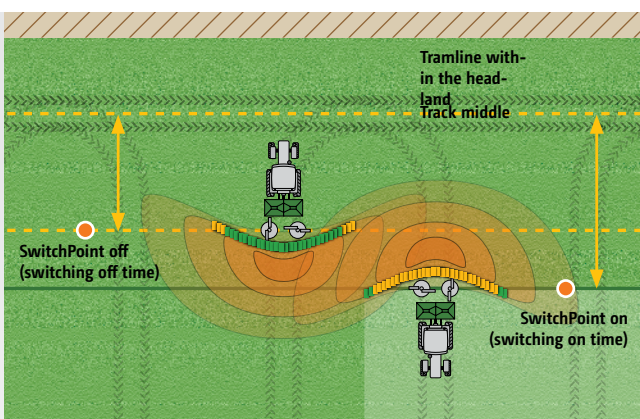

✔ **SwitchPoint**

SwitchPoint allows, when utilising GPS-Switch, to re-adjust the on/off switching points depending on the fertiliser type and the working width. Both values can be taken from the setting chart and entered into the relevant operator terminal.

# Workday made easy –

Make the most of the possibilities!

## **GPS-Maps&Doc**

All standard ISOBUS terminals from AMAZONE can collect and save machine and site-specific data using Task Controller. Part-area, site-specific operation via application maps in either Shape file or ISO-XML formats is also possible.

- ✔ Easy creation, loading and processing of jobs
- ✔ Start a new task straight away and decide later whether the data is saved or not
- ✔ Import and export jobs in ISO-XML format
- ✔ Job summary via PDF export
- ✔ Intuitive system for processing application maps in either Shape file format and ISO-XML format
- ✔ Automatic part-area, site specific regulation of the application rate
- ✔ Indication of inactive field boundaries and automatic field detection when approaching the vicinity
- ✔ Optimum crop management via needs-based application
- ✔ Standard on both AmaTron 4 and AmaPad 2

## **GPS-Track**

The GPS-Track parallel guidance greatly helps with orientation in the field, especially on grassland or in areas without tramlines.

- ✔ With a virtual light bar in the status bar
- ✔ Automatic tramline control via GPS for seed drills
- ✔ Various track modes such as A-B lines or contour following
- ✔ Standard with AmaPad 2
- ✔ Optional with AmaTron 4

## **AmaCam**

Software licence for the display of one camera image on AmaTron 4 and up to two camera images on AmaPad 2.

- ✔ Automatic display of the camera image on AmaTron 4 when reversing



Display of the application map in AmaTron 4



Display of the camera image in AmaTron 4



# AmaTron 4

## Manager 4 all



### Simple and convenient operation as intuitive as your tablet

Why not handle a terminal as intuitively as a tablet or a smartphone? With this in mind, AMAZONE has developed the operator-friendly AmaTron 4 which offers a noticeably smoother operational procedure, especially when it comes to job management. The AmaTron 4, with its 8" multi-touch colour display meets the highest expectations and offers maximum user-friendliness. A swipe of the finger or use of the App carousel allows quick changes between applications and the simple and clearly structured operating menu. A useful MiniView, a freely configurable status bar as well as a virtual light bar make the use of the AmaTron 4 particularly clear and convenient.

Machine operation (UT, Universal Terminal) in day and night mode

#### Benefits of AmaTron 4:

- ✔ Automatic full screen mode when not in use
- ✔ Automatic display of the touch buttons via a proximity sensor
- ✔ Practical MiniView concept
- ✔ Actuation via the multi-touch colour display or soft keys
- ✔ Particularly intuitive and user-friendly
- ✔ Field-related documentation
- ✔ Practice-oriented and intelligent menu navigation
- ✔ Practical quick-start menu with import and export of job data, help windows, day/night mode and the AUX-N assignment
- ✔ One camera input and automatic reversing detection
- ✔ Free trial period for all chargeable licences
- ✔ AmaTron Connect – for the optional entry into the digital age

Equipped as standard with:

**GPS-Maps&Doc**



# AmaTron Connect

New ways of comfortable, networked operation

With AmaTron Connect, AMAZONE provides a digital interface to a smartphone or tablet. The mobile device and AmaTron 4 are simply connected as a hotspot. AmaTron Connect enables use of the AmaTron Twin App as well as data exchange via agrirouter and the myAmaRouter App.

## AmaTron Twin App Clear display enhancement

The AmaTron Twin App offers the driver even more comfort during work, as any GPS functions in the map view can also be operated via a mobile device, e.g. a tablet, in parallel with machine operation on the AmaTron 4.

*Now download the free App and try the DEMO in the App.*



Alternative map views with AmaTron Twin – clear display of the machine and its part-width sections, as well as buttons on the right hand side of the mobile device.



Everything in view at all times with the AmaTron Twin App and the holder kit for a tablet for rigid mounting on the AmaTron 4

### Advantages of the AmaTron Twin display enhancement:

- ✔ Use of an existing mobile device
- ✔ Greater clarity – all applications in view
- ✔ Comfortable control of the GPS functions in the map view, in parallel, via the mobile device
- ✔ Clear, authentic representation of the working machine and its part-width sections

# agrirouter –

the independent data exchange platform for agriculture



Watch the video for more details

## Secure data exchange

agrirouter is an independent data exchange platform for farmers and contractors. It enables simple and cross-manufacturer data exchange between machines and agricultural software applications, thereby reducing administration. The user retains full control over the data at all times.

## myAmaRouter App

For the on-line transfer of data between AmaTron 4 and agrirouter

The myAmaRouter App enables data to be exchanged between the AmaTron 4 ISOBUS operator terminal and the agrirouter manufacturer-independent data exchange platform. If an AMAZONE machine is to be used to carry out a task with job data (e.g. application maps), the data can be easily transmitted from a Farm Management Information System (FMIS) to AmaTron 4 via agrirouter and the myAmaRouter App. After the work has been completed, the job can be sent back and is available for documentation in an agricultural software application.

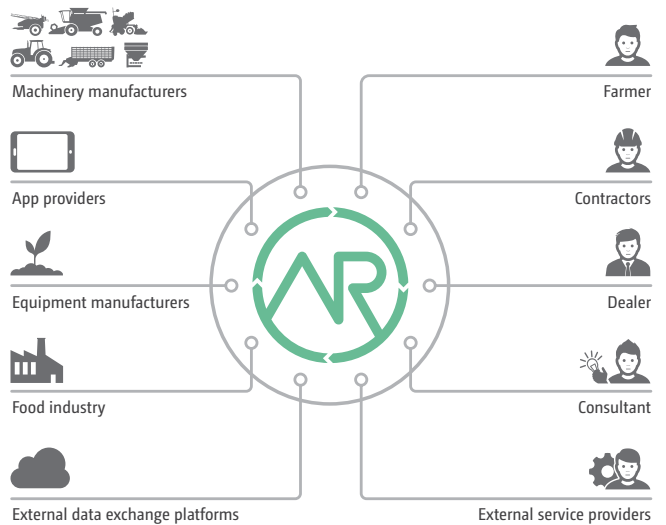

The manufacturer-independent agrirouter enables secure and uncomplicated data exchange.

### Benefits of agrirouter:

- ✔ Simple data exchange between the AmaTron 4 ISOBUS operator terminal and the manufacturer-independent agrirouter data exchange platform
- ✔ Easy and rapid transfer of job and task data without the need for a USB stick
- ✔ More flexibility in data exchange and documentation

## Uncomplicated data transfer. Transparent and secure!



ZA-TS 3200 ProfisPro Hydro

# AmaPad 2

A particularly comfortable method of controlling agricultural machinery

## The new dimension in control and monitoring

With AmaPad 2, AMAZONE offers a particularly high-quality operator terminal. The 12.1" multi-touch colour display is particularly convenient and fulfils the highest demands from Precision Farming. AmaPad 2 is operated solely via touch.

With the practical "MiniView concept", applications which aren't being actively operated at that moment, but need to be monitored, are clearly displayed at the side. When needed, these can be enlarged using "a finger swipe". The possibility of individualising the "dashboard panel" with a choice of display rounds off the user ergonomics.



The most important information at a glance – in full screen mode or in the MiniView

### Benefits of AmaPad 2:

- ✔ High-end ISOBUS terminal with a large touch display
- ✔ Extended MiniView concept enables the simultaneous display of a maximum of four menus
- ✔ Quick-start button and integrated light bar
- ✔ Two camera inputs
- ✔ Day-night mode

Equipped as standard with:

***GPS-Maps&Doc***  
***GPS-Switch basic***  
***GPS-Switch pro***  
***GPS-Track***

Two cameras enable continuous monitoring of the surrounding areas during field work or on the road

## AmaPilot<sup>+</sup> – Everything in one hand!



Thanks to the AUX-N feature, you can operate multiple functions of the machine via AmaPilot<sup>+</sup> or any other ISO-BUS multi-function joysticks.

### The benefits of AmaPilot<sup>+</sup>:

- ✔ Almost every function directly controlled across 3 levels
- ✔ Adjustable palm rest
- ✔ Freely-available key assignment

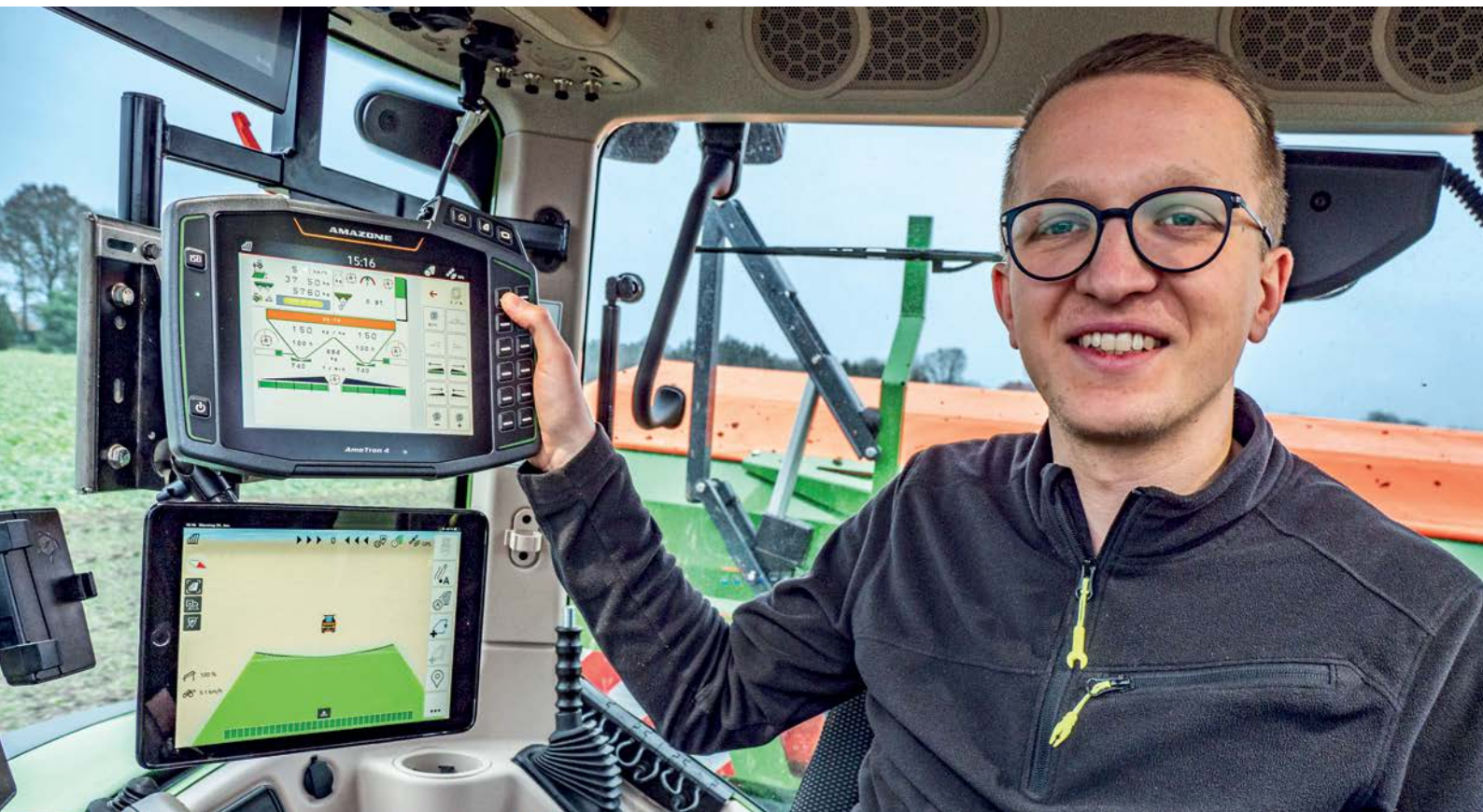



<b>Overview of ISOBUS terminals</b>	<b>AmaTron 4</b> 	<b>AmaPad 2</b> 
Display	Large 8" multi-touch colour display	Large 12.1" multi-touch colour display
Mode of operation	Touch and 12 soft keys	Touch
Interfaces	Serial interface for GPS Two USB ports	
Sensor connection, e.g. nitrogen sensor	via SCU-L adapter	via SCU-L adapter or PeerControl
Job management and actuation via application maps (ISO-XML or Shape file formats)	GPS-Maps&Doc	
Automatic part-width section control (SectionControl**)	GPS-Switch basic * with up to 16 part-width sections or GPS-Switch pro * with up to 128 part-width sections	GPS-Switch basic + pro with up to 128 part-width sections
Parallel guidance aid	GPS-Track * with virtual light bar	GPS-Track with virtual light bar
Automatic track guidance	-	Steer-Ready Set * for the Pantera self-propelled sprayer
Camera connection /Licence *	Single camera connection / AmaCam * with automatic reversing detection	Twin camera connections / AmaCam *

\* = optional / \*\* = Note the max. no. of machine part-width sections

# Spreader Application Center

Exemplary – for more than 25 years

## The settings are crucial!

AMAZONE is providing even better customer service with the Spreader Application Centre. In addition to the already well-established fertiliser laboratory and spreading hall, the Spreader Application Centre now also includes the areas of “Test and Training”, “Data management” and the associated “Knowledge transfer”.

The last two areas are accompanied by a restructuring to address the increasing globalisation and digitalisation of agriculture. The aim of the Spreader Application Centre is to offer to the customer an even better service with regard to fertiliser application.



Fertiliser laboratory



Spreading hall



Test and Training

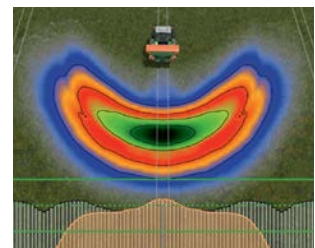

Data management and knowledge transfer

## Only when properly spread is your fertiliser worth its weight in gold

The AMAZONE FertiliserService closely cooperates with well-known manufacturers of spreading material – world-wide to be able to make available to you the best setting values as quickly as possible. AMAZONE is the name for precise spreading charts, worldwide.

## FertiliserService – You can contact us via:

The FertiliserService works across borders, but not only geographically. This is because no matter whether your fertiliser spreader is 1 or 50 years old, we are always by your side with competent and reliable assistance.



Modern fertiliser spreader testing hall

Internet: [www.amazone.net](http://www.amazone.net)  
 E-Mail: [duengeservice@amazone.de](mailto:duengeservice@amazone.de)  
 Telefon: +49 (0)5405 501-111  
 WhatsApp: +49 (0)175-488 9573

AMAZONE fertiliser spreaders can be optimally set up using the free **mySpreader App**:



# mySpreader App

The all-in-one package for perfect spreader adjustment



EasyCheck is an integral part of the mySpreader App

## FertiliserService, EasyCheck & EasyMix

The mySpreader App bundles all the App functions for Amazone fertiliser spreaders into the one App. The intuitive operation and convenient adjustment of the fertiliser spreader lies at the heart of the all-in concept.

### FertiliserService

The FertiliserService App conveniently generates precise adjustment recommendations directly in the field, depending on the model of spreader, working width, fertiliser type and application rate. Thanks to the many samples sent in annually by farmers, fertiliser suppliers and fertiliser manufacturers, the App is constantly kept up-to-date so that the end user has access to current information at the start of every season. A special feature of the mySpreader App: the operator can search for fertilisers by entering the fertiliser name, the chemical composition, the granule size or bulk density, for example.

### EasyCheck

The second element of the mySpreader App is the digital and mobile EasyCheck test kit. In this test kit, plastic mats are simply placed in the field at defined intervals, spread

over and then photographed. EasyCheck then calculates the degree of coverage of each mat. Based on these values, the App suggests improved settings for the lateral distribution of that fertiliser through the Amazone spreader, allowing the operator to rapidly optimise the accuracy of their crop care.

### EasyMix

The mySpreader App is rounded off by the EasyMix App, which works out setting recommendations for blended fertilisers. Different fertilisers are often mixed together to save on the number of applications and so reduce operating costs. This is usually a nutrient-based fertiliser application. However, if the constituents in the blend have different physical properties, precise placement becomes increasingly difficult, especially at increasing working widths. EasyMix determines the best possible compromise between different constituents and suggests the optimal setting values for the ZA-TS and ZG-TS spreaders.

All the settings for the spreader can be transferred from the mySpreader App to the AMAZONE fertiliser spreader via a Bluetooth adapter. This saves time and avoids setting errors, whilst, at the same time, being much more convenient.



## Technical data:

ZA-TS	1400	1700	2000	2200	2600	2700	3200	4200
Working width (m)	15–54							
Hopper capacity (l)	1,400	1,700	2,000	2,200	2,600	2,700	3,200	4,200
– with bolt-on extension S 600 (l)	2,000	2,300	2,600	–	–	–	–	–
– with bolt-on extension L 800 (l)	–	–	–	3,000	–	3,500	4,000	–
Payload (kg)	Super frame	3,200	3,200	3,200	3,200	3,200	3,200	–
	Ultra frame	–	–	–	4,500	–	4,500	4,500
Filling height (m) without rolling & parking device	1.13	1.23	1.31	1.30	1.49	1.42	1.54	1.76
Filling width (m)	2.23	2.23	2.23	2.72	2.23	2.72	2.72	2.72
Overall width (m)	2.55	2.55	2.55	2.92	2.55	2.92	2.92	2.92
Total length (m) without weighing system	1.48	1.46	1.46	1.55	1.46	1.55	1.55	1.68
Drive	mechanical (Tronic) / hydraulic (Hydro)							
Weigh weighing system	as an option with Profis weighing system or ProfisPro including FlowControl torque measurement							
Regulating electronics	ISOBUS communication via AmaTron 4, AmaPad 2 or any other ISOBUS terminal							
Lower link	Super frame	Cat. II linkage dimensions and fixing pins						
	Ultra frame	Cat. III linkage dimensions, fixing pins Cat II or III						
Tractor valves required	ZA-TS Tronic	Not necessary, (1 d/a valve for hyd. rollover cover)						
	ZA-TS Hydro	1 s/a valve + pressure-free return or load sensing for drive (oil capacity 70 l/min), (1 d/a valve for hyd. rollover cover)						
Min. weight (kg) (with spreading vane set TS 20)	471	480	489	539	528	555	573	685

Illustrations, content and technical data are not binding and may differ depending on the level of equipment. Country-specific road traffic regulations apply and must be complied with, meaning that special approval may be required. The permissible axle loads and total weights of the tractor should be checked. Not all the listed combination options are possible with all tractor manufacturers.

## ZA – the spreader

